



TASCAM
TEAC Professional Division

OWNERS MANUAL

644

MIDISTUDIO

NOTES

As regards the resistors and capacitors, refer to the circuit diagram and the PCB assembly drawings contained in this manual.

- * Parts marked with * require longer delivery time.
- * Resistor values are in ohms (Ω) — 1,000 ohms, K — 1,000,000 ohms.
- * All capacitor values are in microfarads (μ) — picofarads.
- * ⚠ Parts marked with this symbol are safety critical components. They must always be replaced with identical components — refer to the TASC parts list and ensure exact replacement.
- * DC is referenced to 0V in this manual, unless otherwise specified.
- * PCB layouts shown are viewed from top (unless stated).
- * Parts not shown in the parts lists or parts highlighted, owing to parts numbers, are not general "ready to supply" parts.

WARNING
Lithium-ion battery pack should be used for portable operation. Do not use other battery packs. Do not use the battery pack in the following conditions:
• In the presence of fire or high temperature.
• In the presence of moisture or humidity.
• In the presence of strong magnetic fields.

SAFETY INSTRUCTIONS

CAUTION:

- Read all of these instructions.
- Save these instructions for later use.
- Follow all warnings and instructions marked on the audio equipment.

1. **Read Instructions** — All the safety and operating instructions should be read before the appliance is operated.
 2. **Retain Instructions** — The safety and operating instructions should be retained for future reference.
 3. **Heed Warnings** — All warnings on the appliance and in the operating instructions should be adhered to.
 4. **Follow Instructions** — All operating and use instructions should be followed.
 5. **Water and Moisture** — The appliance should not be used near water — for example, near a bathtub, washbowl, kitchen sink, laundry tub, in a wet basement, or near a swimming pool, etc.
 6. **Carts and Stands** — The appliance should be used only with a cart or stand that is recommended by the manufacturer.
- 6A. An appliance and cart combination should be moved with care. Quick stops, excessive force, and uneven surfaces may cause the appliance and cart combination to overturn.



7. **Wall or Ceiling Mounting** — The appliance should be mounted to a wall or ceiling only as recommended by the manufacturer.
8. **Ventilation** — The appliance should be situated so that its location or position does not interfere with its proper ventilation. For example, the appliance should not be situated on a bed, sofa, rug, or similar surface that may block the ventilation openings; or, placed in a built-in installation, such as a bookcase or cabinet that may impede the flow of air through the ventilation openings.
9. **Heat** — The appliance should be situated away from heat sources such as radiators, heat registers, stoves, or other appliances (including amplifiers) that produce heat.
10. **Power Sources** — The appliance should be connected to a power supply only of the type described in the operating instructions or as marked on the appliance.
11. **Grounding or Polarization** — The precautions that should be taken so that the grounding or polarization means of an appliance is not defeated.
12. **Power-Cord Protection** — Power-supply cords should be routed so that they are not likely to be walked on or pinched by items placed upon or against them, paying particular attention to cords at plugs, convenience receptacles, and the point where they exit from the appliance.

13. **Cleaning** — The appliance should be cleaned only as recommended by the manufacturer.
14. **Power Lines** — An outdoor antenna should be located away from power lines.
15. **Outdoor Antenna Grounding** — If an outside antenna is connected to the receiver, be sure the antenna system is grounded so as to provide some protection against voltage surges and built up static charges. Section 810 of the National Electrical Code, ANSI/NFPA No. 70 — 1984, provides information with respect to proper grounding of the mast and supporting structure, grounding of the lead-in wire to an antenna discharge unit, size of grounding conductors, location of antenna-discharge unit, connection to grounding electrodes, and requirements for the grounding electrode. See Figure below.

EXAMPLE OF ANTENNA GROUNDING
AS PER NATIONAL
ELECTRICAL CODE

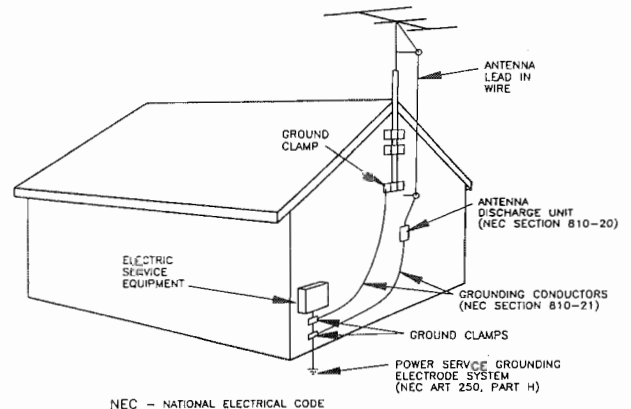

16. **Nonuse Periods** — The power cord of the appliance should be unplugged from the outlet when left unused for a long period of time.
17. **Object and Liquid Entry** — Care should be taken so that objects do not fall and liquids are not spilled into the enclosure through openings.
18. **Damage Requiring Service** — The appliance should be serviced by qualified service personnel when:
 - A. The power-supply cord or the plug has been damaged; or
 - B. Objects have fallen, or liquid has been spilled into the appliance; or
 - C. The appliance has been exposed to rain; or
 - D. The appliance does not appear to operate normally or exhibits a marked change in performance; or
 - E. The appliance has been dropped, or the enclosure damaged.
19. **Servicing** — The user should not attempt to service the appliance beyond that described in the operating instructions. All other servicing should be referred to qualified service personnel.

The 644 Midistudio is different in major ways from previous Portastudios. The basic structure of the mixer, the features of the tape transport, the MIDI implementation, and the electronic switching are all new. To get the most out of your 644, spend some time now to READ THE MANUAL! You'll be glad you did. Even if you're experienced, you'll discover some tricks you haven't tried before.

This manual is divided into sections.

INTRODUCTION: Everyone, from expert to novice, should read this part.

STANDARD OPERATION: This covers the "how to" procedures of basic multitrack recording with the 644. It advances to instructions about using effects, bouncing tracks, and punching in.

MIDI OPERATIONS: After you've worked with and are comfortable with the mixer and the recorder sections, read this if you want "how to" procedures of MIDI synchronization. Non-MIDI users don't need this part.

FEATURES AND CONTROLS: Everyone should use this "what is it?" dictionary that defines every control and indicator on the 644 in detail.

You'll get the best results by having your system set up so you can experiment with it as you read. *Don't* make the mistake of booking a crucial recording session before you've had free time to really get to know your 644.

The 644 Midistudio® is a 4-channel multitrack cassette recorder, a 16 input mixing system with electronic routing control, and a MIDI Tape Synchronizer combined into a single workstation. It's the first Portastudio® expressly designed to meet the challenge of the MIDI revolution. Its mixing section is designed in a new way to accommodate the greater number of line inputs in a typical MIDI studio, up to 16 at once plus 4 effect returns. Each main channel can access up to 4 effects busses, so you can use a variety of different effects (reverbs, delays, choruses etc.) on different inputs. MIDI Tape synchronization with Song Position Pointer (same as that used by the TASCAM MTS-30) is built in, so that the capabilities of MIDI sequencing can be blended with the advantages of multitrack recording.

To make the 644 Midistudio easy to use, TASCAM designed an all-electronic switching system that automates all mixer routing into one central display panel. You can change the settings of the whole mixer by pressing just two buttons. This makes each stage of multitrack recording more automatic, so you can concentrate on the creative work instead of getting bogged down in the technical details of moving from tracking and overdubbing to the final mix. Unlike many of the units an electronic musician has to face today that use menus and complicated messages, the Midistudio shows what it's doing with an easy-to-read, black on white LCD screen.

In addition, the Midistudio can be synchronized to other multitracks (like the TASCAM MSR-16 or 238) or to a video tape recorder using the TASCAM MIDIIZER.

For those who are already familiar with previous Portastudio operation, there are two innovations in particular that make the Midistudio different from other units:

Dual Section

Just above the main fader and pan is the DUAL section, with its own LEVEL and PAN controls. The DUAL is called that because it has dual functions. The first function is as an in-line stereo monitor mixer, which allows you to get a mix of tape tracks (and live MIDI-controlled instruments) so you can play along with previous tracks while overdubbing without interfering with the levels being sent to the recorder.

At mixdown time, the dual section converts to its second function: as 8 additional inputs to the main mixer, each with independent pan, level, and effect sends. This LINK feature makes the Midistudio into a 16x2 console, while maintaining a compact size.

Alternatively, the DUAL can be used as a stereo effects send, which in addition to the 2 dedicated AUX sends adds up to 4 possible sends from each of the 8 main input channels.

To summarize, the DUAL section is an independent 8x2 "mixer within the mixer", with its own input selection, master volume control, and output jacks that can also be linked to the main mixer outputs without repatching.

Dual used as MONITOR

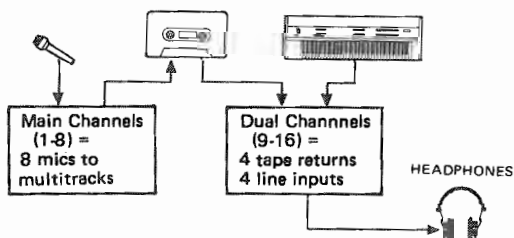

Dual used at MIXDOWN

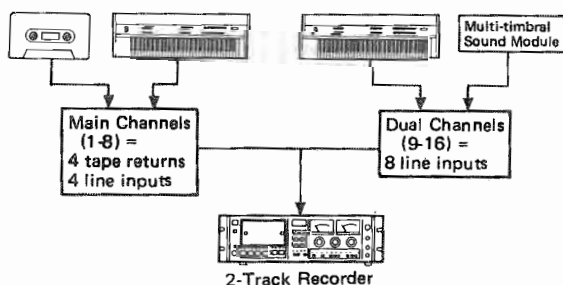

Dual used as STEREO EFFECT SEND

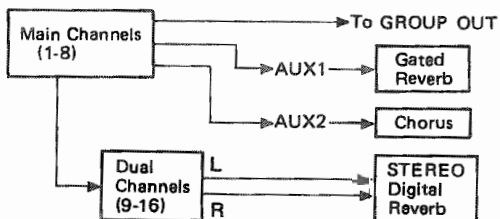

Assignment Board and Display

Every switch on a mixing console, no matter how many there are or what company made them, performs one of three relatively humble tasks:

1. Where FROM—called "input selection" or "sourcing"
2. Where TO—called "assignment"
3. How MUCH—called level, gain, attenuation, trim, mute, on/off, etc. etc.

Recording mixers need all these switches so they can perform the three processes of multitrack, in which the signal flow through the mixer changes direction.

The Three Steps To Multitrack Recording

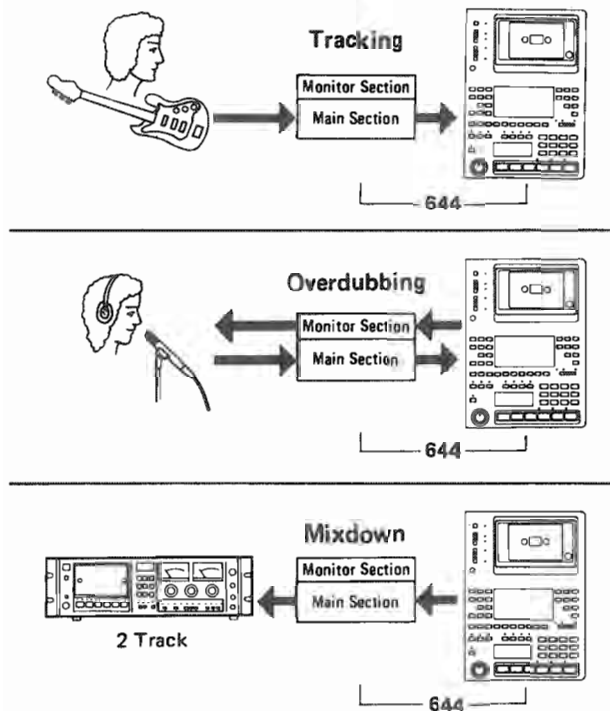

The Midistudio is equipped with an electronic routing display and switch matrix to control the signal flow. To change a setting, you select what you want to do—for example, select LINE for the main input channel source—then press the channel buttons under the screen. The change in settings is shown by the black squares next to LINE in the LCD display.

These black squares show that MAIN channels (1-8) are assigned to Groups 1 and 2.

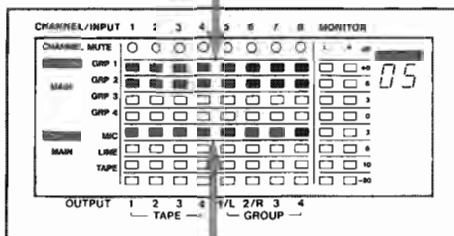

These show that the MAIN channels (1-8) are getting their inputs from the MIC jacks.

With mechanical switches, you might have had to press dozens of separate switches to go from overdub to mixdown modes. But because the switching of the Midistudio is electronic, a computer chip can memorize your most frequently used switch settings in a preset we call a SCENE. For example, Scene 1 could be your "tracking" setup, Scenes 2 & 3 can be "overdub" settings, and Scene 12 could be "mixdown" assignments. The 644 Midistudio can store 99 different scenes in its battery-backed up memory. All you have to do is change scenes (by pressing UP, DOWN, or the number keys, then RECALL), and everything changes for you. You can successfully use the Midistudio just by stepping through the scenes preset by the factory; but it's easy to make scenes customized for your particular studio.

You can also have the scenes change via external MIDI commands (see p. 26, "MIDI Automation Section").

MIDI Tape Synchronizer

MIDI sequencers and rhythm machines can be synchronized using MIDI clocks, digital pulses that set the tempo of the machines. A MIDI Tape Synchronizer (MTS) built-in to the Midistudio can read this MIDI timing information and translate it into a special FSK sync tone that can be recorded onto track 4 of the multitrack recorder. During playback, the MTS reads the FSK sync tones off of track 4 and translates them back to MIDI clocks that the system uses to stay in tempo (sync) with the tape recorder. Since the MTS is built-in, the audio connections and level setting is done automatically. All you have to do is connect the sequencer to the MIDI jacks of the 644.

Unlike some other methods of tape sync, the built-in MTS has MIDI Song Position Pointer capability. This allows you to locate the tape to any location within a song and have your MIDI sequencer and rhythm machine go to the correct part of the sequence. You no longer have to go back to the beginning of the song as you may have had to with the sync tones generated by the sequencer itself. No more time lost waiting through the first verse when you want to punch-in to the chorus!

Depending on the size and complexity of your system you can have many different MIDI keyboards, modules, and rhythm machines all controlled by a sequencer which is synchronized to the tape using the MTS tone. Some MIDI keyboards and modules are *multitimbral*, meaning one instrument can play different sounds, sometimes through different output jacks, at the same time.

You can use these MIDI instruments as *virtual tracks*, meaning that they play along "live" with the tape tracks all the way through final mixdown. Or, you can get more out of your MIDI system by *layering tracks*, actually recording a sound onto tape, then using the same synthesizer (or group of synthesizers) to record a different sounding layer on another track.

Multitrack Recorder

The 644 records on readily available standard (Philips) Compact Cassette tape, high bias Type II. You can record on any or all four tracks of the 644 at any time.

With proper operating techniques, it is not necessary to leave a guard band between music and sync tone tracks because of the low crosstalk of the TASCAM heads. Using DBX noise reduction at high speed (3 3/4 i.p.s.), the sonic quality of the 644 is only exceeded by reel-to-reel recorders with noise reduction.

The transport controls of the Midistudio are microprocessor operated, allowing high reliability and automatic functions that make the unit easier to use:

- REHEARSE and AUTO IN-OUT use the counter to electronically mark punch-in and out times. Once you have set the points, you can practice an insert several times before actually recording, with machine precision each time.
- A three position autolocator (MEMO 1 and 2 and Zero) allows key positions to be located automatically
- REPEAT allows a section to be played over and over for rehearsal

- There are two counter displays, one showing the current position and the other showing an autolocate or punch point
- The counter display can show either reel revolutions or acts as a timer showing how long the transport has been in PLAY mode

In addition, the transport capstan motor is *servo-controlled*, so that the tape speed can be increased or decreased with the PITCH CONTROL to match pitch or for special effects. The capstan can be externally controlled by a synchronizer (such as the TASCAM MIDiiZER) connected to the ACCESSORY 2 interface of the 644 so the tape will "lock" to another recorder, either audio or video, using SMPTE Time Code.

The 644 can be remotely controlled by the optional RC-88 which puts the transport controls up to 5 m (15 feet) away. Punch-in and Punch-out can be engaged using the optional RC-30P or RC-60P footswitch, which gives you an "extra hand" in the recording process. (The RC-60P can also be used to recall scenes on the assign board.)

NOTE FOR U.K. CUSTOMERS

U.K. Customers Only:

Due to the variety of plugs being used in the U.K., the provided PS-M1 power supply unit is equipped with no AC plug. Please request your dealer to install the correct plug to match the mains power outlet where your unit will be used as per these instructions.

IMPORTANT

The wires in this mains lead are coloured in accordance with the following code:

BLUE: NEUTRAL
BROWN: LIVE

As the colours of the wires in the mains lead of this apparatus may not correspond with the coloured markings identifying the terminals of your plug, proceed as follows.

The wire which is coloured BLUE must be connected to the terminal which is marked with the letter N or coloured BLACK. The wire which is coloured BROWN must be connected to the terminal which is marked with the letter L or coloured RED.

This product is manufactured to comply with the radio interference of EEC directive "82/499/EEC."

Bescheinigung des Herstellers/Importeurs

Hiermit wird bescheinigt, daß der/die/das

MISCHPULT MIT MAGNETTONBANDGERÄT 644

(Gerät, Typ, Bezeichnung)

in Übereinstimmung mit den Bestimmungen der

AMTSBLATT 163/1984, VFG 1045/1984, VFG 1046/1984

(Amtsblattverfügung)

funk-entstört ist.

Der Deutschen Bundespost wurde das Inverkehrbringen dieses Gerätes angezeigt und die Berechtigung zur Überprüfung der Serie auf Einhaltung der Bestimmungen eingeräumt.

TEAC CORPORATION

Name des Herstellers/Importeurs

THIS DIGITAL APPARATUS DOES NOT EXCEED THE CLASS B LIMITS FOR RADIO NOISE EMISSIONS FROM DIGITAL APPARATUS AS SET OUT IN THE RADIO INTERFERENCE REGULATIONS OF THE CANADIAN DEPARTMENT OF COMMUNICATIONS.

LE PRESENT APPAREIL NUMERIQUE N'EMET PAS DE BRUITS RADIOELECTRIQUES DEPASSANT LES LIMITES APPLICABLES AUX APPAREILS NUMERIQUES DE CLASSE B PRESCRITES DANS LE REGLEMENT SUR LE BROUILLAGE RADIOELECTRIQUE EDICTE PAR LE MINISTERE DES COMMUNICATIONS DU CANADA.

Precautions and Recommendations

Track Format and Compatibility

The 644 Midistudio uses either the standard cassette speed of 4.75 cm/sec. (1-7/8 ips—*inches per second*) or the high speed of 9.5 cm/sec. (3-3/4 ips). Here is a comparison of various cassette formats:

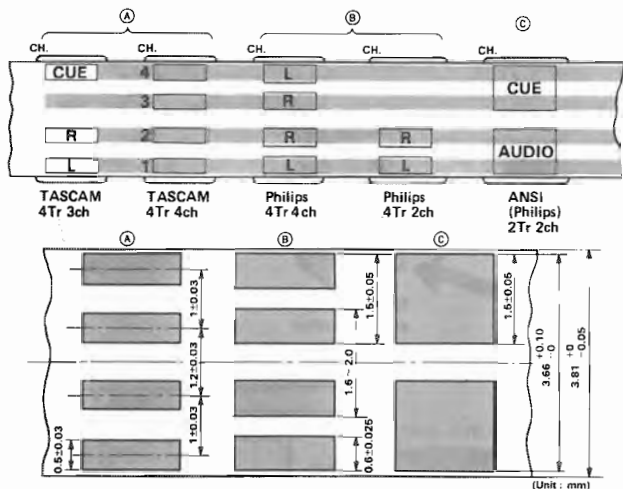

Tapes recorded on stereo cassette recorders will only play back on the first two tracks of the 644 at low speed. Tapes made on all 4 tracks of the 644, will not play back properly on stereo cassette recorders. Material recorded on the 644 must be mixed down to stereo for general distribution.

The 644 Midistudio, like all multitrack cassette recorders, records and plays the tape in one direction only. The 644 needs the entire width of the tape to record its four tracks, eliminating the option of recording on both sides (actually, it's both *directions*). Therefore, you should decide which side (side "A" or side "B") you want to use and use that side exclusively. It's a good idea to get into the habit of consistently using the same side on all multitrack tapes.

Accidental Erase/Record Protection

To protect a finished master tape, it is necessary to punch out both record protect tabs. Even though you are recording in only one direction, the 644 Midistudio uses the entire width of the tape, as mentioned above. If, for example, you remove only one of the tabs, you could accidentally insert the cassette into the 644 backwards and erase all four tracks of the master.



Tape Type

The 644 Midistudio is internally adjusted for HIGH BIAS "Type II" tape. This means that for best results, you should only use tapes of this type. Examples would include TDK SA, Maxell XL-II or equivalent formulations. We strongly suggest that you select one good quality brand and use it exclusively. The time you spend creating your multitrack master is much more valuable than the money you save by buying inferior tape. The cassette shell essentially becomes a part of the 644's transport. Poor quality shells can cause wrinkles, snarls and shredding of the edges of the tape with use. Even small scratches on the tape oxide can cause "dropouts" (temporary loss of signal) on one or more of the tracks. High quality tapes are less likely to cause problems in the long run.

Tape Length

Use the shortest possible tape for a given work. It is not unusual to play a tape 100 times before you are finished, so select a cassette length that is as close as possible to the length of the program you plan to record. Cassettes C-60 length and shorter are often made from thicker stock than longer cassettes.

The tape used in C-120 cassettes is extremely thin and can cause winding problems, crimping, wrinkling, and other damage to the oxide coating of the tape which will destroy your work. Don't use C-120s in the 644.

Remember that at 2X normal speed, and the "one-side-only" 4-track single direction format means that you have only 1/4X normal play time:

(approx.)

C-30	7.5 min.
C-46	11.5 min.
C-60	15 min.
C-90	22.5 min.

CHANGING THE MEMORY BACK-UP BATTERY

The included battery lasts about 5 years. We recommend you to change the battery in advance to prevent accidental erasure of the contents of the 99 scene memories. If the battery has run low, when you turn on the 644 you will see the switch settings of factory preset scene 01, instead of the last scene you used. For information on how to change the battery, consult TASCAM or your nearest TASCAM dealer.

ADVARSEL!

Lithiumbatteri – Eksplosionsfare.
Udskiftning må kun foretages af en sagkyndig,
og som beskrevet i servicemanualen.

The Recording System

There are six elements to a complete recording system:

- Multitrack recorder
- Mixer
- 2 Track recorder
- Input devices (microphones, synthesizers)
- Output devices (headphones or amp and speakers)
- Effect processors

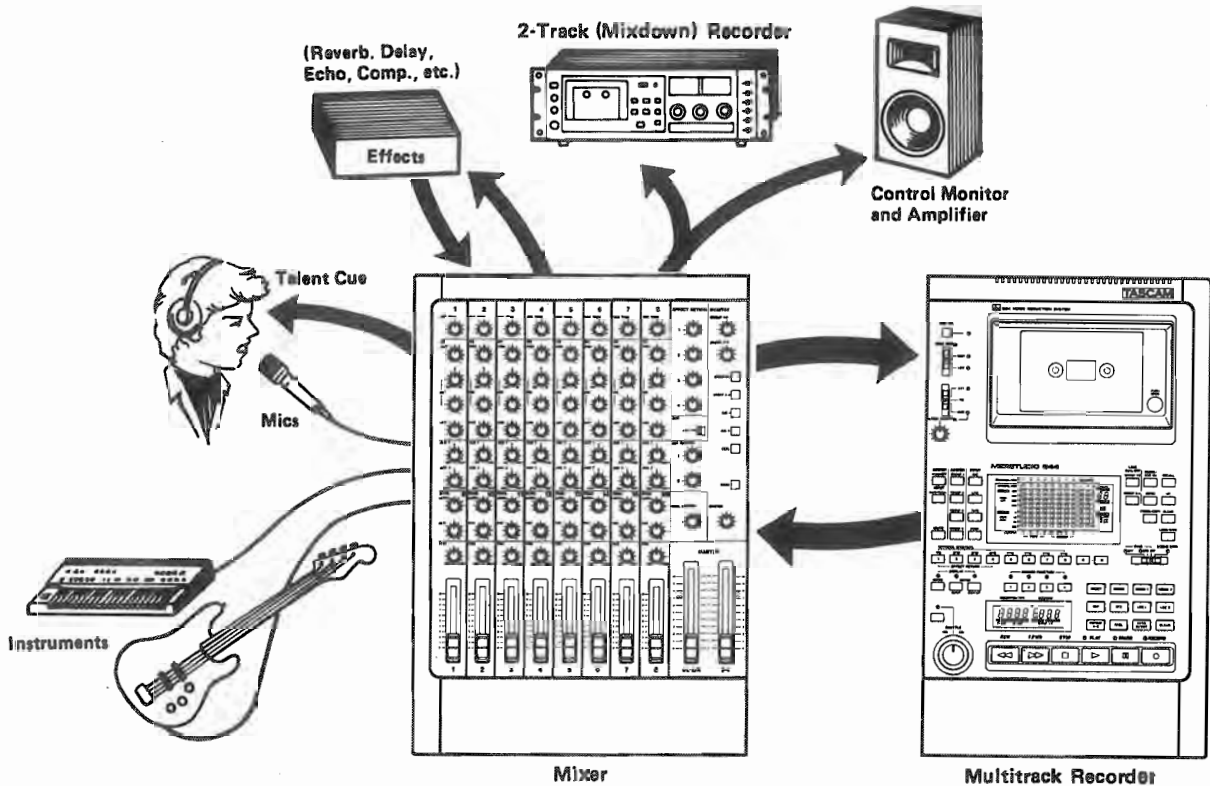

The Midistudio combines the mixer and the multitrack recorder into one unit, virtually eliminating the time consuming and confusing patching that used to be associated with multitrack audio production. Even though they are internally wired together, it is important to recognize that they behave as if they were separate. When you plug into Input 1, you're plugging into the mixer, not track 1 of the recorder. You have to use the mixer controls to *assign* that input to whatever track of the recorder you want it to go to.

Understanding the Mixer

The mixer of the 644 functions as a traffic control center for all the other elements of the complete system. It takes multiple inputs, processes them for level and tone, and sends or assigns them to multiple outputs. A large system, like the mixer, is easier to understand if you break it down into several subsystems. The DUAL section (p. 4) is a subsystem of the mixer.

Main Mix: The largest of these subsystems is the MAIN mix (faders 1-8). It receives signals from the input jacks, routes them through equalizers and faders, and then combines or GROUPS them together so many inputs can

be recorded onto one track. The Main mix is most often used to cut basic tracks, overdub, ping-pong, and at final mixdown. The Main Mix system can also be used as a sound reinforcement mixer.

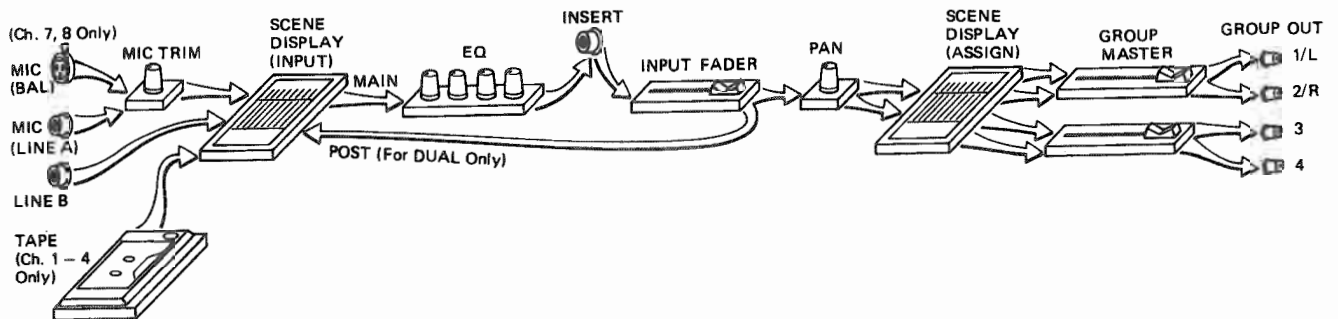

Aux Mix: AUX 1 and AUX 2 are two subsystems that allow the 644 to send separate mixes to external devices, such as digital delays and reverb units or headphone amplifiers. They are similar to the "Effect Send" or "Foldback" controls on many mixers, but have more flexibility – each AUX can choose its signal from two different points in the Main or Dual mix. The AUX 1 and AUX 2 OUT jacks on the back panel can then be connected to your signal processor, and the processor's output(s) can be connected to the EFFECT RETURNS, or even back to another mixer input. Note that the EFFECT RETURNS are actually four specialized inputs to the Main Mix, since they can also be assigned to the four groups.

Aux 1 always gets its signal from the MAIN signal path, either before (PRE) or after (POST) the main fader. This allows it to be used as either an independent headphone feed (similar to "monitor" or "foldback" controls on a PA board) or as an effect send from channels 1-8.

Aux 2 can get its signal either from the MAIN path (POST, same as Aux 1), or from the DUAL path. This allows it to be used as a second effect send from main channels 1-8, or as the only effect send from dual channels 9-16.

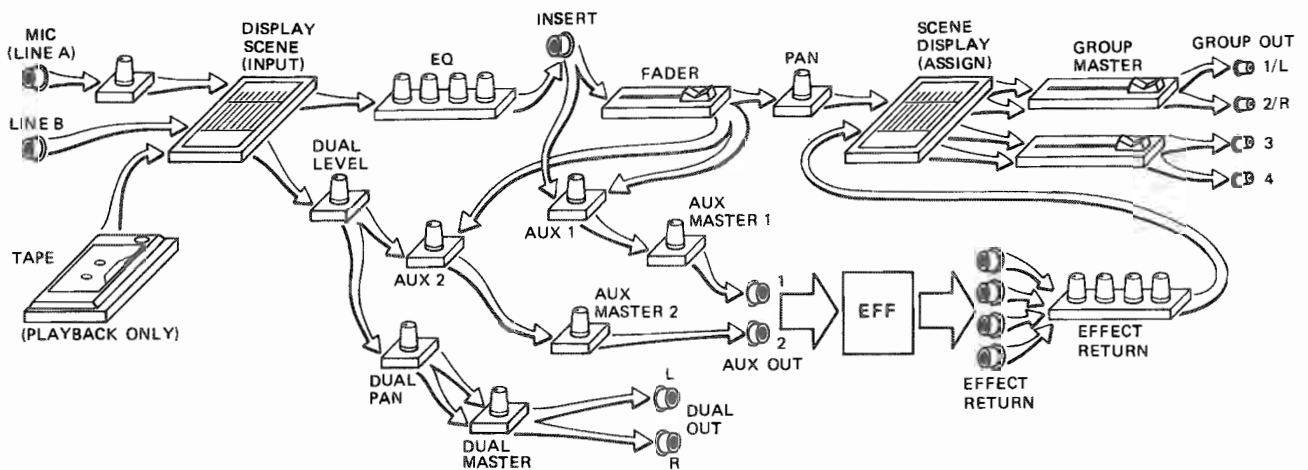

Operations Section

Following are step-by-step instructions for the basic procedures of the Midistudio. They will give you the basic experience you need to fully understand the sections that explain the capabilities of the 644 in detail, so you can customize it for your own situation.

PLAYING BACK A PRERECORDED TAPE

Before actually beginning recording, try playing a tape with audio already on it. It doesn't matter if it was made on a standard cassette or what it sounds like; this exercise is so you can become familiar with the 644 and check your connections.

Preliminary Setup

Preset the controls: To avoid problems, begin with the power off. Make sure the following controls are set:

- Bring all the faders down.

In the channels:

- Set all MIC TRIMS to full counter-clockwise (7 o'clock)
- Set all EQs, AUX 1 and 2, and PAN controls to center (12 o'clock)

In the master and monitor section:

- Turn all the EFFECT RETURNS, AUX and DUAL MASTERS, both MONITOR GROUP LEVELS, and the monitor MASTER off (to full counter-clockwise (7 o'clock))
- Put all the MONITOR SWITCHES (from GROUP 1-2 to MONO) in their OFF position (up)

In the transport section:

- Set the TAPE SPEED to LOW.
- Set the PITCH CONTROL to FIX.
- Turn the DBX Noise Reduction OFF.
- Set the SYNC switch to OFF.

Insert a cassette: Press on the cassette door's lower right hand corner, and it will spring open. Insert a prerecorded tape. Close the door.

Plug in headphones or monitor amplifier and speakers: Make sure the headphones are stereo. Inserting any mono jack into the headphone jack shorts out the headphone amplifier. If you'd rather use a monitor speaker setup, connect the MONITOR OUT jacks on the back of the 644 to the inputs of your power amplifier.

Turn the power on. Put on your headphones.

Listen to a cassette

1. On the numbered CHANNEL keys, press "0" then "1". This should make "SCENE 01" appear in the two-digit display: it's a special factory preset (unless your unit has already been used by someone else, in which case you should see p.19, "Restoring Factory Presets").

OR, press the UP or DOWN keys until "SCENE 01" appears in the display.

2. Press RECALL. The scene number will stop blinking. (To recall scenes you can optionally use the RC-60P footswitch. When connected to the REMOTE UP/DOWN jack on the front and pressed, it has the same effect as pressing UP or DOWN and then RECALL).

3. Press PLAY. The cassette should start to move.
4. Find the three DISPLAY keys and indicators, and press METER OUTPUT. If there is signal on the tape, it should make at least some of the first four meters (TAPE 1-4) move.
5. Press the DUAL switch in the monitor section.
6. Bring DUAL LEVEL controls 9 and 10 up to the 2 o'clock position.
7. Bring the DUAL MASTER up until the monitor level meter reads in the middle, averaging around 0 dB.
8. Slowly increase the rotary MASTER control in the monitor section until you get a comfortable level in the headphones.

Further experiments to try: Now that you're hearing something, here are some things to try before moving on to recording.

- Turn the DUAL PAN 9 and 10 controls. You should hear the stereo image shift in your headphones.
- Bring up the DUAL 11 and 12 controls. If it's a standard cassette with material recorded on both sides (A and B) of the tape, you'll hear the other side backwards.
- Put the PITCH CONTROL into VARI, and turn the knob to increase and decrease the speed.
- Turn the first two AUX 2 controls all the way to the left (DUAL). In the MONITOR section, press AUX 2 and turn off DUAL. As you slowly increase the AUX MASTER 2 control, you'll start hearing the tape again.

Notice that if you turn down the DUAL 9 and 10 pots, it will affect the signal: this is because AUX 2 gets its signal from the DUAL pots when it's turned to the left.

After you're done with these experiments, return the controls to their original positions. Press STOP and remove the prerecorded cassette.

RECORDING THE FIRST TRACK

Prepare to record

1. Press on the cassette door's lower right hand corner, and it will spring open. Insert a high quality blank High Bias (Type II) tape. Close the door.
 - Press the DBX switch so that the LED goes ON.
 - Set the TAPE SPEED to HIGH for the best quality recording.
2. Plug a source (microphone or instrument) into MIC (LINE A) jack: 1/9. If the instrument has its own volume controls, set them to maximum.

Select the input and output for the channel:

3. Press **SCENE** in the **DISPLAY** keys above the shuttle knob. The LED indicator will go on, and the LCD display will show you the current switch status.
4. On the numbered **CHANNEL** keys, press "0" then "1". This should make "SCENE 01" appear in the scene display.
5. Press **RECALL**. The scene number will stop blinking.

NOTE: For now, make sure Channel 1's main PAN control (the one closest to the fader) is set to center. If it is set hard right, signal can not go to group 1 even though it is assigned there.

Set the input level

6. Press **METER INPUT** in the **DISPLAY** keys above the shuttle knob. The assign display will disappear, and the LCD is now acting as an input meter.
7. Play the instrument or speak into the microphone while slowly increasing the **MIC TRIM**. When the meter goes up to the "0" indication in the middle, the level is set correctly. If the instrument peaks the meter even at the lowest settings of the **MIC TRIM**, you'll have to turn down the level on the instrument.

Set the output level

8. Press **METER OUTPUT** in the **DISPLAY** keys above the shuttle knob.
9. Increase the Channel 1 fader to the shaded area between 7 and 8.
10. While playing the instrument or speaking into the microphone, slowly increase the **MASTER 1/L-2/R** fader until the meter reads in the middle, averaging around "0 dB".

Set the monitor level

11. In the **MONITOR** section, press the **GROUP 1-2** switch (down position).
12. Slowly increase the **GROUP 1-2 LEVEL** rotary control until the **MONITOR L-R METER** is reading around 0 dB.
13. If you haven't already, put on the headphones and increase the **MASTER monitor rotary control** to a comfortable listening level.

IMPORTANT: Do not change the settings of the **MASTER** and **CHANNEL** faders to adjust the monitor level—change the monitor controls only.

Put the recorder into record mode

14. Press **PLAY** and allow the tape to run for about 15 seconds. This will run the tape leader onto the take-up reel, and put the beginning of the tape in front of the heads.

15. Press the **TRT** key until the **COUNTER/TRT** display is in counter mode. It will show 4 numbers without a colon.
16. Press **RESET**. This "zeros out" the **COUNTER** display, so you can use the **RTZ** (Return to Zero) key when you're done recording to get back to this point on the tape.
17. Press **RECORD FUNCTION** key #1. The red LED above the key will start to flash.
18. While holding **RECORD**, press **PLAY**. The **RECORD FUNCTION**, **RECORD**, and **PLAY** lights will all go on solid, and you are now recording on track one. Perform your first track.
19. Press **STOP**, then **RTZ**. The 644 will rewind the tape to the start position.

Listening to the First Track

1. Press the **RECORD FUNCTION** key #1, so you can't accidentally erase what you've just recorded. Its LED will go out.
2. Listen to the track via the **DUAL** section, as you did in the "Playing Back a Prerecorded Tape" exercise: bring up **DUAL 9** (whose **INPUT** source should still be **TAPE** if you're using factory preset #1), the **DUAL MASTER**, and press the **DUAL** switch in the monitor.

If you are having problems, press **DISPLAY ASSIGN** and make sure that the screen looks like this:

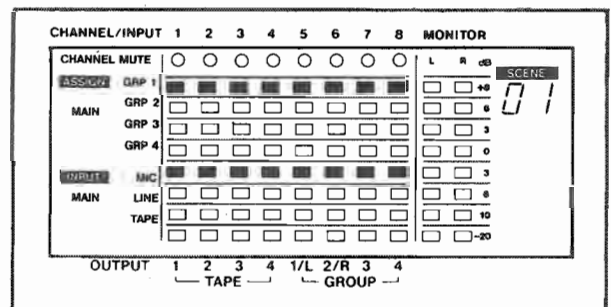

If not, see p. 16 "Using the Scene Display" to make it this way.

At this point, you have completed the first track, also called a take or pass. If the recording quality, level, and performance are OK, proceed to the next step: recording an overdub.

OVERDUBBING

Overdubbing is a procedure consisting of recording one or more additional tracks while a performer (or performers) listens to previously recorded tracks, typically with headphones.

In this quick tutorial, we're going to continue using factory preset Scenes as our basis. **Before performing the following steps press UP to go to Scene 02**, preset for overdubbing onto track 2, and press RECALL.

Set the output level

This is the same procedure as in recording the first track.

1. Press **METER OUTPUT** in the **DISPLAY** keys above the shuttle knob.
2. Increase the Channel fader to the shaded area between 7 and 8.
3. While playing the instrument or speaking into the microphone, slowly increase the **MASTER 1/L-2/R** fader until the meter reads in the middle, averaging around "0 dB".

Set the monitor level

Monitoring is what makes overdubbing different from tracking. You need to set how much you will hear in your monitor of the first track and your live instrument, without disturbing the settings that control how much goes to the tape recorder. (See p. 5. "Tracking, Overdubbing, and Mixdown".)

4. In the **MONITOR** section, press the **GROUP 1-2** switch (down position).
5. While playing your instrument, slowly increase the **GROUP 1-2 LEVEL** rotary control until the **MONITOR L-R METER** is reading around 0 dB.
6. If you haven't already, put on the headphones and increase the **MASTER monitor** rotary control to a comfortable listening level.
7. Assuming the **DUAL 9**, **DUAL MASTER**, and **DUAL MONITOR** switch haven't been touched since you listened to the playback of the first track, press **PLAY**. You will hear the first track in your headphones, along with your live instrument.
8. Adjust the **GROUP 1-2 LEVEL** and **DUAL MASTER** controls until you hear the balance you want in your headphones.
9. Press **RTZ** to rewind the tape to the start position.

Put the recorder into record mode

10. Press **RECORD FUNCTION KEY #2**. The red LED above the key will start to flash. Make sure all other record function keys are off—especially the first track.
11. While holding **RECORD**, press **PLAY**. The **RECORD FUNCTION**, **RECORD**, and **PLAY** lights will all go on solid, and you are now recording on track two. Perform your first overdub.

12. Press **STOP**, then **RTZ**. The 644 will rewind the tape to the start position.

Listen to the overdub

13. Press **PLAY**. Increase the **DUAL LEVEL #10** control to hear the playback of track 2. You can adjust the **DUAL PAN** and **LEVEL** controls to get a stereo monitor mix of the first two tracks.

Performing overdubs 3 and 4

Tracks 3 and 4 can be recorded using almost the identical procedure as above. The differences are:

- Use of preset Scenes 3 and 4
- Different **RECORD FUNCTION** keys
- Use **MASTER FADER 3-4** to set the record levels
- Use the **GROUP 3-4 LEVEL** and switch to hear the "live" instrument while you're overdubbing onto tracks 3 and 4.

Factory preset scenes 01-04 assign all Main inputs to one group at a time. If you want to record to two or more groups simultaneously, use scene 05 for groups 1-2 or scene 06 for groups 3-4, using the **PAN** controls for assignment to either side; or Scene 10 for all 4 tracks at once. See p. 55-6.

MIXDOWN

The last stage of multitrack recording is mixing down your 4 tracks to a stereo master. You will need another tape recorder for this. Any stereo recorder with line inputs will do, but a quality recorder such as those made by TASCAM will ensure that you're not stepping down in quality at this last stage, which to many people is the most crucial since it's the tape you'll actually release outside the studio.

Put the Midistudio into mixdown mode

1. If your 644 still has the factory presets, press **UP** until you arrive at **SCENE 12**. Press **RECALL**. In this preset, **TAPE** appears at the **MAIN** channels 1-4, and is assigned to groups.

- 1-2. Make sure the **ASSIGN DISPLAY** looks like this:

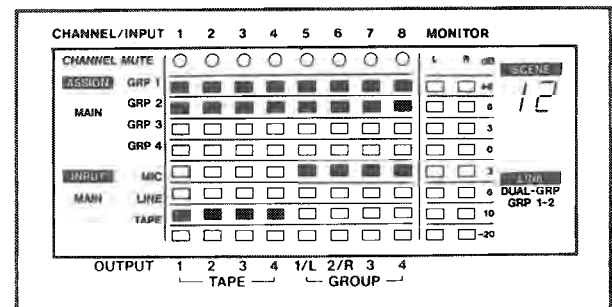

If you don't have factory presets, see "Using the Assign Board" on p. 16 to:

- a. Select **INPUT TAPE** for **MAIN** channels 1-4.
- b. Assign **MAIN** channels to **GROUPS** 1 and 2.
- c. (Optional) If you wish to use **DUAL** as an effects send, select **INPUT POST** for the **DUAL** channels 9-16.

2. Rewind the tape to the start of the take by pressing RTZ. Make sure all RECORD FUNCTION switches on the 644 are off.

Prepare the mastering recorder

3. If your mastering recorder has an input level control, set it to its nominal position. Consult the manual for your recorder to see how to do this. The goal is that when the Midistudio's L/R meter reads 0 dB, the meter on your two-track will also read 0 dB, so there's no confusion.
4. Connect the GROUP OUT jacks 1 and 2 (also labeled L and R) to the line level inputs of your mastering stereo recorder using good quality shielded cable.
5. Put a blank high-quality tape on your mastering deck. Run off fifteen seconds of tape to get past the leader if necessary. Reset the master's counter to zero so you can rewind to that point.
6. Set the mastering recorder so that it will meter input. This depends on the deck: some have their own REC FUNCTION switches, others have an INPUT switch, others must be put into REC PAUSE mode.

Set the output level

7. Press DISPLAY OUTPUT on the 644.
8. Press PLAY on the 644.
9. Set the MASTER 1/L-2/R FADER at the nominal area (shaded area between 7 and 8).
10. Increase the channel faders until the GROUP 1 and 2 meters read between -3 and 0 dB. At this point, the meters on your mastering recorder should be reading the same; if not, adjust the input level control of the mastering recorder. When in doubt, the meters of the master should be your reference.
11. Adjust the channel PAN controls as desired.
 - See p. 21, "Using the Dual" for effects during mix-down.

Set your monitoring level

You can't mix it if you can't hear it. And your monitoring levels need to be variable without affecting the mix feeding the mastering recorder. There are two ways to monitor: source, and tape.

12. SOURCE MONITORING:
 - a. Turn off all MONITOR switches except GROUP 1-2.
 - b. Adjust the monitoring level with the GROUP 1-2 LEVEL and MASTER MONITOR pots.

TAPE MONITORING:

- a. Connect the line outputs of your mastering recorder to the inputs of your monitor amp. Ideally, your monitoring amp has an input switch that will allow it to switch between the 644's monitor output and the 2-track output.

- b. Adjust the output level of your mastering deck for the overall level. Alternatively (especially if your deck's meters follow the output level control), adjust the level using the controls on your monitor amp.

Record the Mixdown

13. Rewind the 644 to the beginning point using RTZ.
14. Press RECORD-PLAY on your mastering deck, or release PAUSE, so it's rolling in record.
15. Press PLAY on the 644.
16. When finished, stop both recorders. Rewind and play the tape on the master. Listen to the results; if you're not satisfied, make notes of changes you'd like to make and repeat the mixdown, making the desired changes.

Advanced Operations

Once you feel comfortable with the basics of tracking, overdubbing, and mixdown on the 644, it's time to dive into more challenging activities: using signal processing, bouncing tracks, punching in, and making your own scenes.

PUNCH-IN OR INSERT RECORDING

It is possible to record over a section of a track containing an error without having to re-record the entire part. This procedure is called "punching in" or "insert" recording. The 644 can manually punch-in with the RECORD (●) button, the RECORD FUNCTION switches, or the optional RC-30P or RC-60P footswitch. You can also program an automated punch-in and out with the REHEARSAL and AUTO IN/OUT functions.

Before moving on to punch-in recording, check to make sure that you are on the scene you've used for originally recording the track you now intend to insert on. If you are on any other scenes, recall the original scene (by pressing UP/DOWN or numeric keys then RECALL).

Manual Punch-In

METHOD A: Punching with the RECORD button or footswitch

Get ready to record

1. Press the RECORD FUNCTION switch of the track you intend to insert on. Its LED will start blinking.
2. If you are fixing a mistake right after the original recording, don't touch any volume settings—they should be the same. If not, adjust the monitor and record levels as you would for a normal overdub.

Preroll

3. Rewind the tape to a point before the punch-in point. You may wish to press MEMO 1 so you can return to this point.
4. Press PLAY. You will be able to hear both your live instrument and tape playback. Adjust the MONITOR GROUP LEVEL to control the "live" instrument, and the DUAL to control tape playback.
5. When the tape reaches the desired punch-in point, press RECORD or the footswitch to start recording. The RECORD LED and RECORD FUNCTION LED both stay on.
6. Punch out by pressing STOP, PLAY, or the footswitch.

METHOD B: Punching with the RECORD FUNCTION button

This method is sometimes called "rolling in record" and requires that you have a free hand.

1. After the recording and monitoring levels are set, make sure that all tracks are SAFE (no LEDs blinking).
2. Press RECORD and PLAY together to start playing the tape. The RECORD LED will blink, showing that the 644 is in record-ready mode.

3. Press the RECORD FUNCTION button of the punch-in track when the tape reaches the punch-in point. The LEDs above the Track and RECORD button will light steadily, showing that recording is taking place.

4. To punch out, press RECORD FUNCTION again (you could also press STOP or PLAY).

REHEARSAL AND AUTO IN/OUT PROCEDURES

The 644 MIDISTUDIO can automatically punch in and out for you, relying on its built-in counter for reference.

Rehearsing Inserts (RHSL)

Before you actually record an insert, the 644 allows you to "preview" the punch-in and out points with its special REHEARSE function. During a rehearsal, the tracks in record ready mode will be muted between the punch in and out points but won't actually record. What you hear in your monitor mix will be the same as during recording; so if a punch accidentally overruns existing material you can change the points until you've got exactly what you want. During a rehearsal, the MEMORY display will show you what's going to happen next, and when.

- At any time before you enter the OUT point (in step 7 of the procedure below) you can press STOP, PAUSE, REW and F.FWD to abort the procedure and enter new points. Once you have entered the OUT point those transport buttons, though active, don't clear the memory points. PLAY and RECORD have special effects during the RHSL SET procedure as specified below.

Entering the automatic preroll and punch in/out points

1. Check to make sure that the four RECORD FUNCTION LEDs are all off. If you press at this point the FUNCTION key of the punch-in track, you cannot hear the track after you enter the In point and before you enter the Out point.
2. Adjust the record and monitoring levels as you would for a manual punch in.
3. Press the RHSL switch. "RHSL" will appear blinking in the counter window. As long as this indicator appears, you can't actually record: you are "rehearsing" your insert recording.
4. Press PLAY (▶). Whatever number is on the left side counter will become the preroll START point, as indicated by the appearance of "START" under the RHSL indicator. The right side MEMORY display window will show the counter position you started at.
If you press PLAY again before performing the next step, that point is memorized as a new START point and the old one is erased from memory.
5. At the punch-in point, press RECORD (●) or the footswitch. "IN" will appear in the counter display, and the MEMORY display will show the counter position you punched-in at. The LED over the RECORD button will blink (which shows you that recording is not actually taking place).

6. Press **PLAY (▶)** or the footswitch when the tape reaches the punch-out point. "OUT" appears under the counter, and the MEMORY display shows the Punch out point that has been put into memory. The RECORD LED will go out.

After a 3-second postroll, the RHSL indicator will turn on solid, the MEMORY display will show "START", while the tape will automatically rewind back to the START point. You are now in Rehearsal Play mode.

NOTE: The rewinding tape will overshoot the start counter position. This is intentionally done to ensure the tight uniform preroll playback start. The punch-in track's output will be muted until the start point is reached.

Rehearsing the punch-in ("dry run")

During Rehearse Play mode, the MEMORY display will show you the counter position of the upcoming IN and OUT points.

1. Make sure that the 644 is in "Rehearsal Play" mode with the RHSL indicator on solid. Press the **RECORD FUNCTION** switch of the track you want to punch-in on. Its LED will start blinking. Check to make sure that all other tracks are in safe mode.
2. Press **PLAY (▶)** or **RC-30P** footswitch. You will be able to hear the tape just from the MEMORY START point. The MEMORY display will show the upcoming punch-in point.

You can use **REW** then press **PLAY** to start listening to the tape from a point lower than the preset START point.

3. When the tape reaches the displayed IN point (i.e., when the COUNTER readout matches the MEMORY readout), "START" will change to "IN". The MEMORY display will switch to show you the upcoming punch-out point. The track's output will mute, so you will hear only your "live" instrument. The RECORD LED will start blinking and the RECORD FUNCTION LED will light on solid.
4. When the tape reaches your preset punch-out point, "IN" will change to "OUT". You will be able to hear the tape again (along with your "live" instrument). The RECORD LED will go out and the RECORD FUNCTION LED will again blink, indicating that the "dry run" record is over.
5. After a 3-second postroll, the tape will automatically rewind to the "MEMORY START" point, ready for as many rehearsals as you wish.

Practice the performance until you are sure that you will get it right when actually recording. Remember, once you punch-in over existing material, that original signal is erased!

To Leave REHEARSAL Mode:

- To definitely QUIT rehearsal without recording at any time, press **CLEAR**. The RHSL memory points will be

cleared and "RHSL" will disappear from the display.

- To temporarily leave rehearsal, press **STOP**, **PAUSE**, **REW** or **F.FWD**. The MEMORY display will continuously show the start point regardless of where you move the tape to. To resume rehearsal press **PLAY** when you *are* at a point lower than the IN point. If you *are not*, "START" should be blinking, asking you to rewind the tape back to any point behind the IN point.
- To change the memory points, press **CLEAR** and go through the SET procedure again.
- Ejecting the tape or turning the power off will clear the RHSL memory points.

Actual, Auto Punch-in

Once you're sure your performance and the in/out points selected are correct, you're ready to actually record the insert. RHSL should be on solid in the display. All tracks should be in SAFE mode except the ones you intend to record.

1. Press the **AUTO IN/OUT** key. "AUTO IN/OUT" (blinking) replaces "RHSL" in the display.
2. Press **PLAY (▶)** or the footswitch to begin the preroll from the START point. The upcoming IN point will be displayed in the MEMORY window.
3. When the tape reaches the MEMORY IN point, the punch-in track will automatically enter the actual record mode, and the RECORD button and track RECORD FUNCTION LEDs will turn on solid. New material is being recorded, erasing the original part. The MEMORY display will show the upcoming OUT point.
4. When the tape reaches the MEMORY OUT point, the 644 punches out of Record. The RECORD LED will turn off and the track's FUNCTION LED will be blinking.
5. After a 3-second postroll, the AUTO IN/OUT display will go on solid and the tape will automatically rewind to the MEMORY START point.

To review the result, press **PLAY (▶)** or the footswitch. The tape will play the entire segment and rewind to the start point.

To try again, re-enter AUTO REC by pressing **AUTO**. "AUTO IN/OUT" will start blinking again and you can record another pass using the same points.

To quit the auto in/out procedure at any time, press the **CLEAR** switch. "AUTO IN/OUT" will disappear from the counter display. By hitting **CLEAR**, you erase all of the memory points, START, IN and OUT.

To abort a take and rewind to the start, press **PLAY**, **STOP**, **REW**, or the footswitch before the OUT point is reached. "AUTO IN-OUT" will blink, showing you're still in AUTO REC mode.

To set new points, you must press **CLEAR** and **RHSL** again.

ABOUT PUNCHING IN

Selecting in and out points: For both musical and technical reasons, when punching in or out of a track, you must select points that are "in the clear", i.e., in the pauses between phrases or notes. It sounds unnatural and makes the insert noticeable if you record a new note before the old one has ended, or are holding a note as you punch in or out. For this reason, some session players leave a beat or two of silence between passages they might want to edit later. Making inserts well requires some practice. Many engineers count bars and beats to keep track of the punch in and out points and hit them on cue. Because of the spacing between the erase and record heads, you need to anticipate your in/out points by a fraction of a second for extremely tight cues.

BOUNCING TRACKS (PING-PONG)

The recording capability of the 644 Midistudio is not limited to four tracks. You can "bounce" or combine tracks you have recorded to an empty track, and then replace the original tracks with new material. A bounce is like a mixdown, except you are recording to one of the tracks of the 644 instead to an external recorder.

While you are bouncing, you can add live sources to the combination of the prerecorded tracks. Any mixer channel that is not being used for Tape can be used to add a new part.

Using these techniques, it is possible to get ten "passes" onto tape, without re-recording any part more than once. Thanks to the quality of the 644's recorder section, it's hard to tell the difference between original and bounced tracks, if you follow the proper steps.

In this example, we will combine material from tracks 1-3 plus a live synthesizer onto Track 4.

Prepare the mixer

1. If you are using factory preset scenes, go to **Scene 09** and press **RECALL**. The screens should look like this:

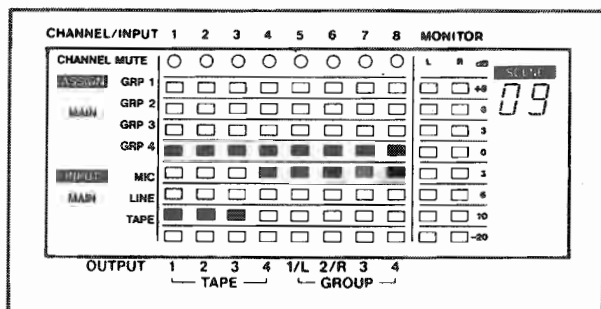

If you don't have this, make the assignments following "Using the Scene Display to Create Your Own Scenes", col. 2 of this page, or load factory presets following p. 19, "Restoring Factory Presets."

2. Bring up the **MONITOR GROUP 3-4** level control. Turn off all other **MONITOR** switches except Group 3-4. During a bounce, it's important that you don't hear anything in the mix except the mix feeding the tape recorder.
3. Press the **DISPLAY OUTPUT** key so you can meter Group 4.
4. Plug the synthesizer into any input feeding the main mixer (in the preset, MIC ins 5-8).

Prepare the recorder

5. Press the **RECORD FUNCTION** switch for track 4. Its light should start to blink. All other **RECORD FUNCTION** switches and lights should be off.
6. Rewind the tape to the beginning of the song.

Set recording levels

7. Set the **MAIN FADERS** to their nominal position.

8. Press **PLAY**. Slowly increase the **GROUP 3-4 MASTER** fader until the **GROUP** meter reads around 6 dB. If you are adding live sources to the mix, play them and adjust the level. Get the mix you want. If you wish, you can add effects to the mix.

9. Rewind the tape to the start of the selection.

Bounce the tracks

10. Press **PLAY** and **RECORD**. Track 4 will record a copy of what is on tracks 1-3, plus any live instrument you add to the mix.

11. At the end of the selection, press **STOP** and rewind to the beginning. Do not change the settings of any controls yet.

Listen to playback

12. In the **MONITOR SWITCH** section, turn **GROUP 3-4's** switch off, and turn **DUAL** on. The factory preset brings only **TAPE 4** to the dual, nothing else. Turn up **DUAL 12** and **DUAL MASTER** to hear playback.

Repeat bouncing

Once you are totally satisfied with the mix on track 4, you can record new material on tracks 1 and 2, then bouncing them onto track 3 the same way you bounced onto track 4. Of course, this will erase the "first generation" tracks, but you have a "second generation" copy on track 4.

USING THE SCENE DISPLAY TO CREATE YOUR OWN SCENES

Once you have become familiar with the basics of multi-track recording using the factory presets, you will want to make customized presets to fit your own studio. There are 99 different scenes possible in memory. By creating your own scenes you can:

- Set up a library of often-used scenes that you can recall with just a few keystrokes
- Set up a chain of scenes that follow your own habit of recording in sequence

- Create a series of scenes that mute unused channels for quiet recording

The **SCENE** display is designed to show you the switch settings of the mixer section and change them if necessary. To keep the screen at a reasonable size, it doesn't show everything at once. Two keys (ASSIGN MAIN/EFF and INPUT MAIN/DUAL) toggle sections of the display to show some settings, and hide others. Other keys are used to change settings, which then can be saved in memory as a SCENE. Even when a display is "hidden", its switch settings are active and can be copied from one scene to another. A SCENE in memory consists of all switch settings: main and effects assign, main and dual input, dual-group links, and channel mutes.

Understanding the Switch Settings

The switches on the 644, like switches on any other recording mixer, control three things:

WHERE FROM: Where is the signal coming from? The Midistudio calls this INPUT select. The possible sources for a channel include MIC, LINE, TAPE, or POST.

WHERE TO: Where does the signal go to? In the Midistudio, there are four GROUPS or mixes that are connected directly to the input of the four-track recorder and also to the GROUP OUT connectors. The Midistudio calls this ASSIGN.

Another "where to" switch setting, on the right hand side of the display, is called LINK DUAL-GROUP. This can send the left and right outputs of the DUAL submixer to the Group 1-2 and Group 3-4 outputs if desired.

HOW MUCH: Most controls on a mixer are "how much" controls. The CHANNEL MUTE is in this category.

In summary, each black square in a SCENE display stands for an electronic switch that's turned on, showing where from (Input), where to (Assign), or how much (Channel Mute).

"Hidden" Displays. There are more switches than the assign display can show at one time. At any given time, about half of the settings are "hidden", although they are still active.

ASSIGN is divided into MAIN and EFF. In MAIN you are setting the "where to" of main input channels 1-8. In EFF you are setting the destination of the four effect returns.

INPUT is divided into MAIN and DUAL. In MAIN you can select the input sources for main channels 1-8; in DUAL you select the sources for dual channels 9-16.

Scene-related displays: On the right hand side of the display is the SCENE number and MEMORY indicator. Once you have made your switch settings, these indicators will help you store them permanently into memory.

OPERATION of the Scene Display

When you want to change the settings of a scene, there are three steps:

- a. Display the data you want to change (you can't change what you can't see). If the display was in a METER mode, the display will automatically

switch to the scene display the moment you press any assign or input key (except MUTE).

- b. "Arm" the particular routing you want to take—choose the groups you want to assign, or the source you want to select (they show that they're "armed" by blinking in the display).
- c. Press the keys of the channels you want to change.

That's all there is to it.

Selecting Inputs

1. Press the **INPUT MAIN/DUAL** key. The MAIN and DUAL indicators will alternately appear in the display under INPUT. The black squares will change if the settings are different. Leave it in whatever section you wish to change.
2. Press the **INPUT** source key you want (MIC, LINE, TAPE or POST). The indicator of the source you've selected will flash, and the 644 is now "armed" in that mode. Note that you cannot select POST unless you are on the DUAL screen.
3. Press the numbered **CHANNEL** keys for the channels you want to switch to the new source. A black square will appear in the channel column, in the row corresponding to the input you've chosen, and any other inputs that were on previously will turn off—there can only be one input per channel. You will also notice that "MEMORY" appears under the scene number, to show you that the changes you are making are in a temporary memory area.
4. To choose a different source, repeat steps 2 and 3. When you are finished with your setting, proceed to "Saving Scenes" on p. 18.

Assigning to Groups

1. Press the **ASSIGN MAIN/EFF** key. You will see the MAIN or EFF indicators appear in the left upper half of the display (under ASSIGN), and the black squares will change if the settings are different. Leave it in whatever section you wish to change.
2. Press the **ASSIGN GROUP** key you want (GROUP 1, 2, 3 or 4). The indicator of the group you've selected will flash, and the 644 is now "armed" in that mode. You can select as many groups at once as you wish.
3. Press the numbered **CHANNEL** keys for the channels you want to assign to the new destination. One or more black squares will appear in the channel column, in the row corresponding to the groups you've chosen. You will also notice that "MEMORY" appears under the scene number, to show you that the changes you are making are in a temporary memory area.

Note that because there are only four EFFECT RETURNS, only the first four CHANNEL keys have any effect while you are in ASSIGN EFF mode.

4. To turn a group off, repeat steps 2 and 3. The second time you press a channel key, the groups will turn

off. When you are finished with your setting, proceed to "Saving Scenes" below.

Notes:

The moment you press any of the ASSIGN or INPUT keys to the left of the display screen, the display automatically switches to ASSIGN mode. After you are done, press DISPLAY INPUT or OUTPUT to see the meters again.

You must make your assign, mute or input selection before pressing the channel keys. One of the indicators must be flashing to show you it is "armed". If you press the number keys first, it has the effect of changing the scene to that number. If you accidentally do this, simply press CLEAR to return to the original status.

Ways to leave an edit mode:

- Press the ASSIGN or INPUT keys so their indicators stop flashing
- Enter a different mode.
- Press CLEAR.
- Press DISPLAY INPUT or OUTPUT
- Press RECALL

Setting Channel Mutes

Unlike the other scene edit modes, you can turn mutes on and off, and the display will remain in INPUT or OUTPUT METER mode.

1. Press the MUTE key. "Channel Mute" will begin to flash.
2. Press the numbered CHANNEL key of the channel you want to turn on or off. A black dot will appear at the top of the column when a channel is muted. You can only mute the MAIN channels 1-8; the DUAL channels do not have mutes.
3. To turn a mute off, simply press the CHANNEL key again until the black dot turns off.

Linking the Dual to the Group Outputs

You can add the DUAL channels 9-16 into the main group mix anytime you want to record more than eight instruments to a track at once. This can be done either for the first tracking or at final mixdown. During overdubs the dual-group links should be OFF so the dual can be used as an independent monitor.

1. Press either of the LINK DUAL-GROUP keys. The "Link" indicator will appear, along with the groups you have selected. Any DUAL PAN controls that feed the left side of the mix will go to odd-numbered groups (1 and 3), and the right side feeds groups 2 and 4.
2. To turn the links off, press the LINK button again. When both links are off, the "LINK DUAL-GROUP" indicator disappears completely.

Saving Scenes

Any changes you make to the scene setting—mutes, links, assignments or inputs—are only temporary. You need to store them to one of the memory locations, otherwise they will be lost when you turn the power off.

"MEMORY" indicator: Right under the two-digit scene number display, this indicator shows that you have made some changes to a scene. You can think of it as a temporary "buffer" memory, that you can carry UP and DOWN to other memory locations where they can be permanently stored.

The MEMORY indicator will

- a. blink when any changes are made to a scene
- b. turn solid when the STORE/COPY key is pressed

To store or make a copy of a scene

1. Finish making changes to a scene, or press STORE/COPY to copy an unchanged scene into the MEMORY buffer.
2. Go to the scene number you want to store the memory in, using the CHANNEL number keys, or by using the UP and DOWN keys.
3. Hold the STORE key and press SCENE/MIDI CH. The contents (if any) of the scene number will be replaced by the memory buffer, and the MEMORY indicator will go out.

To return to the original version of a scene

This can be done only if you haven't done the STORE-SCENE procedure above.

1. Press CLEAR. The MEMORY indicator will go out, but the switch settings will stay at the edited version.
2. Press RECALL. The original unedited scene settings will become active again.

To clear a scene

1. Recall the scene whose switch settings you want to clear.
2. Hold the CLEAR key and press the SCENE/MIDI CH key. The contents of the scene will totally be cleared.

Saving All Scenes to Data Tape

When you've invested a lot of time in 99 scenes, you don't want them to disappear by accident or design. The TAPE SAVE feature of the 644 allows you to take all the scene data in the 644's memory banks and save it onto standard cassette tape. It serves as a backup copy, or long-term storage area.

● If you have a MIDI data filer or MIDI devices that have the function and want to save scenes to these, see next page for the procedures you have to follow.

1. Insert a blank cassette into the tape well.
2. Press the RECORD FUNCTION switch for Track 4. The light will begin to blink.
3. Press PLAY and RECORD. The record lights will turn solid.
4. Turn the SYNC switch to the SCENE DATA position.
5. Press the LOAD/SAVE key until "SAVE" appears under the scene number display. There will be a pause; if the DISPLAY is in OUTPUT mode you will see signal on Tape 4. The scene number will then begin to count upwards from 01 to 99; this takes a few minutes.

6. When saving is complete, the tape will automatically stop. Take the cassette out of the well and store it in a safe place. You may want to punch out the record protect tabs of the cassette so the data cannot be accidentally erased.

Loading All Scenes from a Data Tape

This is the procedure to follow when you want to replace the entire memory contents of the 644 with what's on a data tape. There's no safe way to replace only some of the scene data and not others.

Remember, when you load a data the current memories in the 644 is erased. If necessary, save them first using the procedure above.

1. Insert the data cassette into the tape well.
2. **Cue up the tape.** Listen to track 4; you'll hear a solid tone then a warbling tone. The warbling tone is the beginning of the data; cue the tape up a few seconds before that begins.
3. Turn the **SYNC switch to the SCENE DATA position.**
4. Press the **LOAD/SAVE key** until "LOAD" appears under the scene number display.
5. Press **PLAY.** When the warbling tone starts, the scene number will begin to count upwards from 01 to 99; this takes a few minutes.
6. When loading is complete, the tape will automatically stop. You will find that the scene contents are now what was stored on tape.

Saving All Scenes to MIDI Data Filer or Properly Equipped MIDI Equipment

1. Connect the 644's MIDI OUT to your MIDI filer's MIDI IN.
2. Set the MIDI channel of the 644 to match the filer's receive channel, and get the MIDI filer ready to receive data. Consult the manual for your data filer as required. As for the MIDI channel setting of the 644, see the paragraph with the corresponding heading on page 26.
3. Turn the **SYNC switch to the SCENE DATA position.**
4. Press the **LOAD/SAVE key** until "LOAD" appears under the scene number display.
5. Hold the **STORE/COPY key** and press the **LOAD/SAVE key** again; "LOAD" will change to "SAVE". There will be a pause, then as the scene data is sent out (as exclusive messages) to the MIDI filer, the scene number will count upwards from 01 to 99; this will take a few seconds.
6. When saving is through, "SAVE" will switch back to "LOAD". Operate the filer to save the received data as per instructions in the manual for your filer.

Loading All Scene Data from MIDI Filer

1. Connect the 644's MIDI IN to the MIDI filer's MIDI OUT.
2. Set the MIDI channel of the 644 to match the data filer's send channel, and have the filer enter Bulk Out Ready mode.
3. Turn the **SYNC switch to the SCENE DATA position.**
4. Press the **LOAD/SAVE key** until "LOAD" appears under the scene number display.
5. Have the filer start sending out the scene data. The scene number will begin to count upwards from 01 to 99; this takes a few seconds.
6. When loading is through the scene number "99" will blink. You will find that the scene contents are now what was stored on MIDI filer.

Restoring Factory Presets

If you want to restore all the factory presets 01-12, hold CLEAR and turn the power on. You'll find all the 01-12 presets recovered at once. You cannot restore individual presets.

CAUTION: If you have customized any scenes, 01 thru 99, they will all be erased as you restore the presets. If you want, save them first on tape or MIDI filer as per instructions above.

USING EFFECTS WITH THE 644 MIDISTUDIO

Effects and signal processing is one of the areas where you can really start to have fun customizing your sound, and develop your own unique recording style. Because there are so many possibilities, it also can be confusing. There are many different effect units on the market, all with different controls, types of inputs and outputs, and other characteristics. Read the manual of your effects device, and the following sections to get the complete story of what's possible for your particular situation.

1. **In-line processing:** The processing that's easiest to understand doesn't involve the Midistudio directly at all. You can plug your instrument directly into the input of the effect device, and plug the output of the device directly into a line input of the Midistudio. The whole signal gets processed (flanged, doubled, limited, delayed etc.), and only one instrument can use that processor. Effect pedals for guitar are typically used this way.
2. **Insert processing:** This is closely related to in-line processing. There are eight special two-way send/receive jacks on the back panel called INSERT jacks. Each one has the effect of inserting a signal processor into the main channel (1-8) signal path right after the INPUT switch. Whatever input (mic, line, or tape) chosen for that channel can be sent to its own individual external processor (typically an EQ or compressor), and then returned directly into the channel path. This requires a special Y-cable with a

stereo 3-conductor tip-ring-sleeve phone plug on one end, split to two cables with mono plugs, one for the input (send) to the device and one for the output (return). (The TASCAM PW-2Y and PW-4Y can be used for this purpose). With INSERT only one instrument can use a processor at a time. It has several advantages, though:

- a) The signal at the insert jack has already been preamplified and equalized. This means you can put a microphone signal through a line level processor (most effects pedals can't take mics directly).
- b) It's easy to move a processor from one channel to another, just by moving the insert cable from one jack to another. It's also easy to disconnect the effect by simply unplugging the insert cable.
- c) Certain devices, notably graphic equalizers and compressor/limiters, are designed for in-line or insert use, dedicated to one instrument at a time.
- d) It's possible to have a different effect device on each channel.

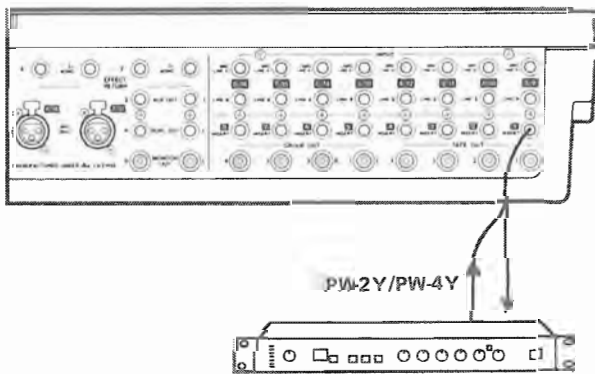

3. **Send/return mix processing:** This is the most common method of effect processing, especially for reverb and delay. It allows a number of different channels to use the same effect, while allowing you to control how much effect is mixed with each channel. Each of the 16 mixer channels can send signals to the AUX 1 or AUX 2 outputs on the back panel. These outputs can then be connected to the input of effect devices. The processed signals from the devices come back into the mix via the EFFECT RETURNS. Finally, the effect is mixed onto one of the groups with the EFFECT ASSIGN screen. This whole path—from the auxes to the reverb and back into an effects return—is called an effects loop. The AUX system controls how much signal goes to the reverb unit; the EFFECT RETURNS control how much comes back from the reverb unit.

See p. 9, "Aux Mix", to see a diagram of how the signal flows through the Aux system.

Setting Effect Send Levels

The goal is not to distort the device, while staying above the noise that effect units generate. To get the best signal-to-noise from most effects units, you should send it as strong a signal as you can. With a properly set input signal in the Midistudio, the channel AUX turned up to about 3 o'clock (POST), and the AUX MASTER at about 2 o'clock, you should get a fairly loud signal from the AUX OUT jack. If your effects device has an input level control of its own, it should be set so the meter or signal light of the effects device is just under the overload point on peak signals. When you want to hear less effect overall, turn down the EFFECT RETURN, not the AUX MASTERS.

Setting the output level of effect devices

If the effect send level has been set properly, in most cases the output level should be set as high as possible without clipping (distorting) the Effects Return of the 644, but low enough so that you have a reasonable range of control. If you can get the effect sound you want with the Effects Return control in the 12 to 2 o'clock range, you're in the ballpark. If, on the other hand, very small settings of the Effects Return still give you a mix drowning in effects, turn down the output level of your effect device.

Some effect units have rear panel switches setting input and output level ranges between "+4" and "-20 dB". In this case, try setting the input to -20 (high sensitivity) and the output to +4 (full output level).

Setting the mix/balance control on effect devices

When it's being used in a send-return mix, set the mix/balance of your effect device all the way to "wet" or full processing with no direct original signal. In send/receive processing, the dry signal goes down the Midistudio's CHANNEL FADER to be mixed with the effect return signal on a group master. Therefore, you don't need any "dry" signal coming to the effects return. The mix/balance control is set toward "dry" only when you're using the effects device as an INSERT or in-line processor.

How to connect your effects devices

There is no absolute "right" or "wrong" way to do this—there are several ways, each with its own consequences.

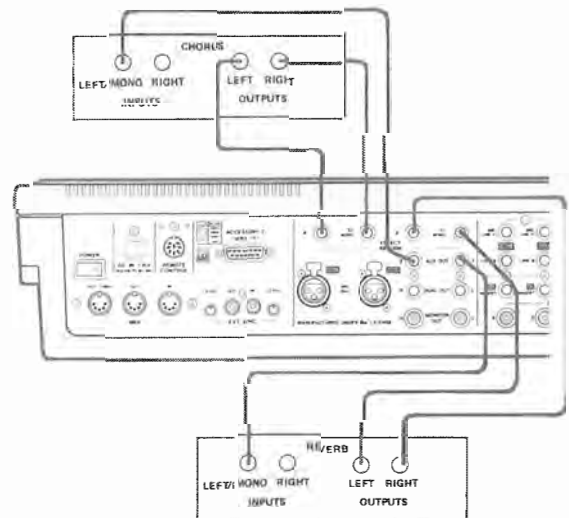

This (diagram on the left page) is the most common method. Aux 1 feeds a reverb unit, which has a synthesized stereo output patched into effect returns 1 and 2. Aux 2 feeds a chorus device with a stereo output patched into effect returns 3 and 4.

Mono returns: If you have an effects device with a single mono output, you can patch its output into a single effects return. Using the effects assign screen, you can assign the return to any or all of the groups. During a final mix to groups 1 and 2, you can assign it to left, center (both) or right.

A special feature of effect returns 1 and 3 allows continuously variable control between left and right if desired: a mono effect connected to RETURN 1 will also go to desired: a mono effect connected to RETURN 1 will also go to RETURN 2 if nothing is plugged into the RETURN 2 jack. By assigning EFF RTN 1 to group 1, and EFF RTN 2 to group 2, you can "pan" the mono effect anywhere between the left and right by adjusting the level of the RTN 1 and 2 controls.

Putting the same effect on all 16 inputs (SUM)

If you want to use one effect device for signals from both the MAIN channels 1-8 and the DUAL channels 9-16, press the SUM switch. This is a "where to" switch that links the AUX 1 and AUX 2 submixes together. AUX 1 in POST position sends signals from channels 1-8, and AUX 2 is used in DUAL position to send from channels 9-16. You can plug the output of either AUX 1 or AUX 2 to the effect device — they will both be the same.

NOTE: In order to use Aux 1 and 2 as separate sends, make sure the SUM switch is OFF!

Patching effects to an input channel: There's no law that says the output of an effects device must be plugged into an EFFECT RETURN, either. They can also be plugged into LINE inputs, and sent to either the MAIN or DUAL mix, if you are cautious about one thing: make sure the AUX 1 and AUX 2 pots of those channels are set to the center (off) position. Otherwise, you will be sending the output of the effect device back to itself, which is a kind of feedback. If the effect device is a digital delay, feedback has the same effect as a regeneration (number of echoes) control. An advantage of returning effects to a main channel is that you can EQ the effect return.

To record reverb onto a track: Simply assign the return to the track being recorded (using the ASSIGN EFF screen) and adjust the controls for the sound you want.

To hear reverb in the headphones but not record the reverb: Assign the effect return to a group that's not being recorded (for example, assign it to group 4 while you're recording on tracks 1 and 2). By turning up the GRP 3-4 monitor level, you'll hear the reverb, but the recording will be "dry".

Using the Dual as an effect send

During mixdown, the dual section can serve as an additional pair of effect sends, or as a stereo effect send.

1. Hook the DUAL OUT jacks to the inputs of two effects units (for example, Dual L to a digital delay, and Dual R to a gated reverb). Alternatively, if you have a true (as opposed to synthesized) stereo effect device, the dual can be connected to it.
2. Connect the outputs of the effects units to two effects returns.
3. Set the input of the dual section to POST. By using the DUAL LEVEL and PAN controls, you can set the level of send to the delay and gated reverb from channels 1-8.

Using the Dual as an effect send means that it can't be linked to the main mixer, or as a separate monitor. See p. 4, "Dual Section" for more information.

MIDI Synchronization Section

INTRODUCTION TO MIDI SYNC

The advantages of MIDI Sync operation

If your music includes electronic keyboards and rhythm machines, MIDI sync allows you to use them without using up a tape track. Instead of recording the sound of the keyboard on tape, you record the actual movements of your hands on the keyboard into a sequencer, which is the electronic equivalent to a player piano roll. The advantages are:

- Tape tracks are freed for non-MIDI instruments such as guitars and vocals
- You can try different sounds on the keyboard to see what fits best, while listening to playback
- It's easier to get a "perfect" performance out of a sequencer
- You can change or edit the musical performance in the sequencer as a master tape "evolves" into a final mix—for example a drum part can be totally rewritten after the overdubs are recorded, but still be in perfect tempo
- You can use one sequencer to play many different MIDI instruments simultaneously
- You can use the sequencer to get the parts right, and the multitrack to record each sound on a different track, thereby getting 3 different sounds out of the same synthesizer

You lose one track (#4) to the sync tone, but you gain control of as many MIDI virtual instruments as you can obtain.

On the other hand, MIDI is not magic. Great recordings have been made without it—after all, MIDI is only a few years old. MIDI sequencers vary from the simple to the extremely complex, but all of them require some level of skill and musical knowledge. It's possible to get so tied up in MIDI technology that inspiration disappears; but for those who take the time to practice using it, it becomes an extension to their musical ability.

This section of the manual assumes that you have read the preceding sections of this manual and understand the operation of the 644's mixer and assignment screen. In this section we're going to focus on just those functions that make the Midistudio different from previous Portastudios: the ability to accept MIDI clocks from a sequencer, translate them into a recordable FSK sync tone with song position pointer information, record the tone on Track 4, and when the tape is played back translate that tone back into MIDI clocks and song pointers that allow a MIDI sequencer to "chase lock" the tape tracks and control synthesizers in perfect synchronization.

Click track and sync tone analogy

Before there was MIDI or sync tone, there was the human equivalent: a "click track". This was a metronome that was recorded on one track of the recorder as

a time base for the musicians doing overdubs. The drummer would hear the click track in his headphones, and play along in tempo.

MIDI synchronization is analogous to that. The tape signal recorded on track four is the electronic equivalent of a click track, with the added element of song position pointer ("bar one, click, click, click, bar two, click, click . . ."). The sequencer has an internal metronome or "clock" that it uses to set tempo. It transmits this clock to its MIDI OUT jack, which is connected to the MIDI IN jack of the 644. MIDI can't be recorded directly onto tape, because it is a digital signal at a very high frequency beyond the reach of analog tape.

However, the MIDI Tape Synchronizer (MTS) built into the 644 can translate the MIDI clock signals into a warbling audio tone (called FSK) which can be recorded on tape. If you listen to this FSK, you'll notice that the tone varies according to the tempo of the sequencer. On playback, this tone has to be changed back into MIDI language so the sequencer can "listen" to the clock via MIDI, and follow the tape recorder. This is done by the MTS, which sends clocks to the MIDI OUT of the 644, to be connected to the MIDI IN of the sequencer.

Know your sequencer

You're going to have to open the manual for your sequencer, whatever it may be, to learn the details of how it works. Before you can stripe, you need to know:

1. How to record a sequence
2. How to set the tempo of the sequencer (its internal clock)
3. How to start it and make sure its MIDI OUT jack is sending clocks
4. How to set the sequencer so it will not generate internal clocks when it receives START, but will follow clocks being sent from the 644's MIDI OUT to its MIDI IN. This is called MIDI CLOCK, or EXT MIDI mode.

Note: Many sequencers and rhythm machines have their own tape sync system, and typically have 3 clock modes: INTERNAL, MIDI, and TAPE. Don't be confused—as far as the sequencer is concerned, it's in MIDI clock mode, not tape because the Midistudio is handling the tape sync chore by itself, and sending MIDI clocks to the sequencer.

MIDI TAPE SYNC SAVE MODE

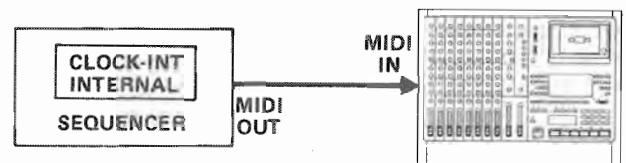

644

MIDI TAPE SYNC LOAD MODE

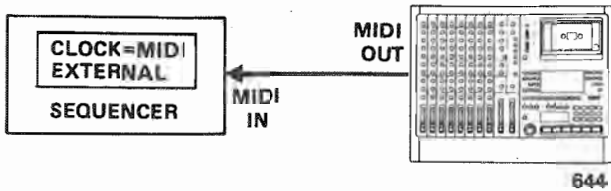

The most common technique is to record a sequence, or a rhythm pattern, into the sequencer before you get involved with the multitrack. In a sense, the tracking procedure now takes place in MIDI instead of to tape. Certainly you need some kind of rhythm pattern that's audibly playing so you can set the tempo correctly.

What is a virtual track? A "virtual" track is an instrument under MIDI control that plays back in synchronization with the tape, whose sound appears at one of the inputs of the mixer. We call it virtual because it isn't actually on the tape, but for all practical purposes behaves as if it was a separate track of its own—it can be changed in level, EQ'd, reverbed, or edited (on the sequencer) separately from the others.

Confusion with sequencer tracks: The word "track" is used by some sequencer makers differently than we do when we refer to a virtual track. A single sequencer track may transmit information to up to 16 different MIDI instruments, each one on a separate MIDI channel. For our purposes, though, a "virtual track" represents a

piece of hardware with a line level signal output, and each of the 16 different instruments represents a "virtual track" to us, even if your sequencer sees them as one stream of data.

THE RECORDING SYSTEM WITH MIDI SYNCHRONIZATION

On page 8, we showed you the traditional multitrack system with its six elements. When you add MIDI sync, you add 4 elements:

- **SEQUENCER:** this is the unit that records MIDI note on-off and other controller information
- **CONTROLLER:** this is a unit that transmits MIDI note and other controller data, typically a master keyboard; it could also be a drumpad, wind controller, MIDI guitar interface, or something else
- **MIDI INSTRUMENT:** this is any unit that can respond to MIDI input by producing a sound.
- **MIDI TAPE SYNC TRANSLATOR:** Since MIDI data can't be recorded directly on tape, there has to be a translator that turns the MIDI clocks into an audible tone. In the Midistudio, this translator is built-in; but you can also choose to use a sync tone generator that's separate or built-in to the sequencer or rhythm machine (see "Using External Sync Devices, page 25"). If your application requires SMPTE time code, you'll need a SMPTE-to-MIDI converter like the TASCAM MIDiIZER.

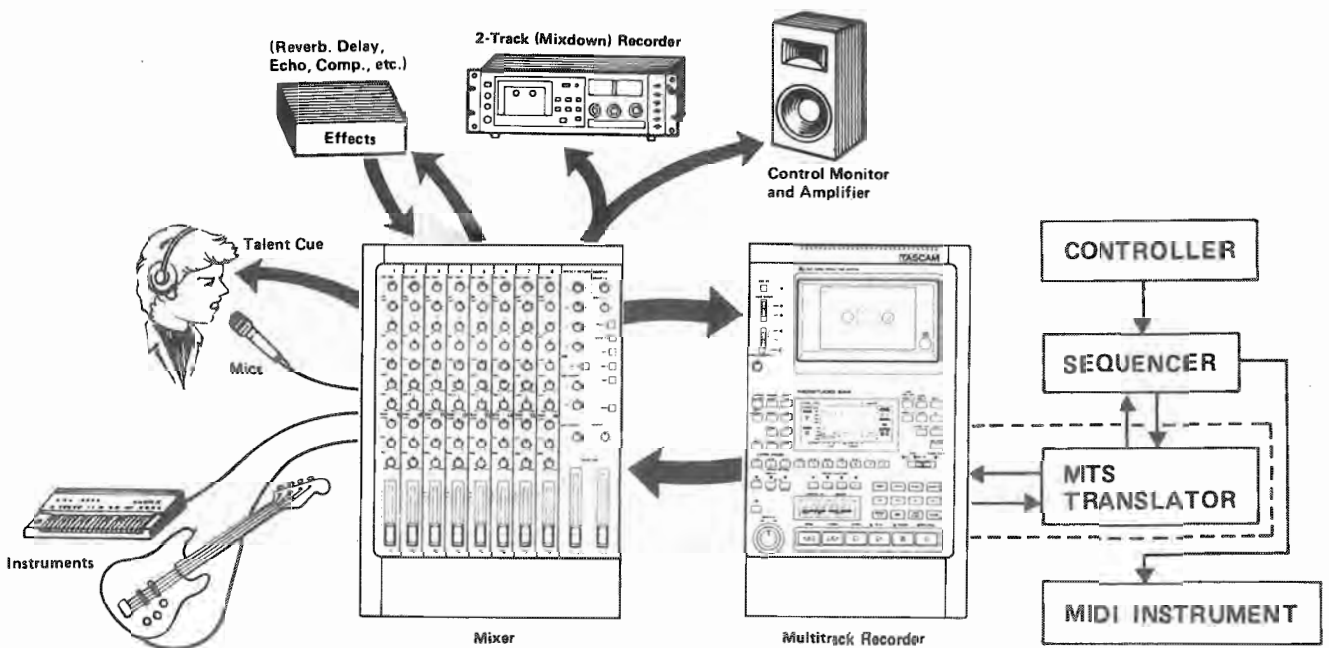

Note that a unit can combine several elements of the MIDI system. A rack module is an example of an instrument, while a synthesizer is typically an instrument combined with a controller. A rhythm machine is an instrument combined with a sequencer, and a "workstation" can combine all three. Many sequencers include their own tape sync translator, though it usually can't take advantage of song pointer like the MTS translator built into the 644 can.

The flow of MIDI Clocks (System Common signals)

Understand that there are two different types of data in the MIDI stream that we're concerned with. **System Common** signals consist of timing commands that sequencers send and receive. They are "broadcast" to every element in the system, but are only used by sequencers. They include START, STOP, CONTINUE, SONG POSITION POINTER, and MIDI CLOCKS.

The Midistudio needs to receive these system common signals from the sequencer during the SAVE operation. Later, the sequencer needs to receive these signals from the Midistudio (during LOAD).

The flow of MIDI Commands (Channel Voice signals)

Another type of MIDI data is the actual performance information: NOTE ON, NOTE OFF (for each of the 128 different notes in the MIDI spec) is the most basic—it's like a command saying, "Play C# in the middle of the keyboard until I tell you to stop." Besides what note is played, it's capable of transmitting *how* it was played—loud or soft (VELOCITY) information, AFTER-TOUCH, and other controllers including PITCH BEND, MODULATION WHEEL, SUSTAIN PEDAL—the possibilities are almost endless. (For a complete list, see the MIDI chart on page 53).

These are called **Channel Voice** messages because the MIDI stream may control different voices, each on its own MIDI channel. A NOTE ON message is always "broadcast" on one channel or another, so that a note meant for the piano doesn't wind up going to the trumpet. (An instrument can also be set to OMNI mode, where it will play any note no matter what channel it's on).

The 644 MIDI Tape Sync feature works only with System Common messages, while Channel Voice messages are handled by the sequencer. The Channel Voice messages themselves are NOT recorded on tape. The MIDI THRU jack of the 644 simply echoes them from the sequencer to the instruments.

However, if desired, the 644 will respond to and issue a limited number of Channel messages. *Program Changes* can change the 644 from one scene to another, and certain NOTE commands can turn individual mutes on and off. For more details on how to do these, refer to the section "MIDI Automation" on page 26.

PROCEDURES FOR MIDI SYNC RECORDING

Just as MIDI sync adds 4 components to the system, it adds one more step to the process: before you can start tracking, you have to record the sync tone. This is called striping the tape. If you could see the bursts of timing information on the tape, they occur regularly in stripes like the lines across frames of film.

Get the sequencer ready to play

1. Enter a song into the sequencer. If there is a tempo setting or conductor track in the sequencer, set that.
2. Set **MIDI Clock out enable** to ON: Some sequencers will not send clocks to the output unless you tell them to.
3. Connect the **MIDI OUT** of the sequencer to the **MIDI IN** jack of the Midistudio using a standard MIDI cable.

Get the Midistudio ready to record the FSK tone

4. Set the **SYNC** switch of the Midistudio to MIDI. The green light will turn on.
5. Press the **SAVE/LOAD** switch of the Midistudio so that the word **SAVE** appears in the LCD window under the number display. You are "saving" the tempo or the sequencer to tape; later you will "load" it back into the sequencer.
6. Put TRK 4 into REC READY. The red LED will start flashing.

Record the MTS Sync tone

7. Press **RECORD** and **PLAY** simultaneously.
8. A few seconds later, press **START** on your sequencer. The display number will begin to increase: it is showing the number of bars (calculated four beats to a bar).
9. When the sequencer stops (either automatically or because you press **STOP** on it), wait a few seconds, then press **STOP** on the Midistudio.

Play back the MTS tone into the sequencer

10. **Rewind** the tape.
11. Connect the **MIDI OUT** of the Midistudio to the **MIDI IN** of your sequencer using a standard MIDI cable.
12. Set your sequencer to follow external MIDI clock input.
13. Turn the **RECORD FUNCTION** of Track 4 to OFF.
14. Press the **SAVE/LOAD** switch so that the word "LOAD" appears under the number display.
15. Press **PLAY** on the Midistudio. When the tape reaches the **START** point, it should start the sequencer. You will be able to hear the virtual tracks that are being controlled by the sequencer.

CAUTION: There are sequencers that can't synchronize to a point within a song even though they are sensitive to the Song Position Pointer. If you have the problem check the manual for your sequencer.

Overdubbing into a sequencer during sync mode

During sync operation, you may want to add more tracks to your sequencer ("virtual overdubs") while listening to the tape. If your sequencer has only one MIDI IN, though, it must be patched to receive clocks from the 644 instead of receiving Channel Voice messages from the controller keyboard. The 644 does not have MIDI Merge, so plugging the controller into the

644's MIDI IN will not solve the problem. There are several other things you can do, however:

- Obtain a MIDI Merge box (2 MIDI IN, 1 MIDI OUT). This will merge the output of the controller with the clocks from the 644.
- If you have a sequencer based on a personal computer, you can obtain a second MIDI interface to plug into another port of the computer, and use it exclusively for clocks from the 644 while the first port is used for the controller.
- Put your sequencer back into CLOCK INTERNAL mode and perform the overdub onto the sequencer tracks without using tape sync.

MIXER OPERATION DURING MIDI SYNC

When virtual tracks are used with the Midistudio, you need to decide what inputs will appear where. A lot depends on whether you want to actually record sounds on the multitrack, or wait until final mixdown.

Three tape tracks plus thirteen other inputs: Since track 4 will be used for recording the MTS tone, you never need to listen to that track—it's internally routed to the translator. So in MIDI sync operation, channel 4 (Main) and channel 12 (Dual) are both free to be used for instrument or mic input.

Hookup Example: Here we have a rhythm machine with

4 outputs—2 for stereo mix, and separate outputs for the kick and snare. We've decided we don't want to record the drums except in the final mix, so we patch the drums into line inputs 4, 5, 6 & 7, and bring them to the DUAL mix so we can monitor them all the time. We have a synthesizer with mono output plugged into line in 8, playing a bass part. We'll save this for the final mix as well, and bring it to DUAL so it can be monitored. We have a sampling keyboard plugged into MIC 4's jack—all we have to do is turn the TRIM control down so the high line level of the sampler doesn't distort the 644's electronics.

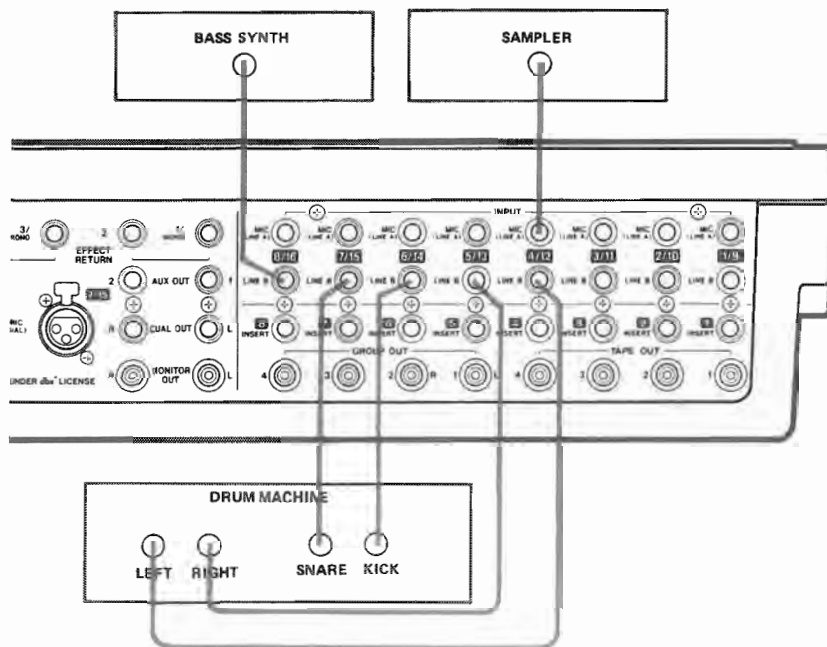

Using External Sync Devices

To use an external sync system instead of the built-in MTS:

1. Take the TAPE SYNC OUT of the external device and plug it into the EXT SYNC IN jack of the 644.
2. Set the SYNC switch on the 644 to EXT. The yellow LED will turn on.
3. Turn the RECORD FUNCTION for Track 4 on.
4. Set the DISPLAY to OUTPUT so you can see the tape level.
5. Set the EXT SYNC IN LEVEL control until Group 4's meter reads 0 dB.
6. Start recording, start the sequencer, and record the tone (this procedure depends on your external device).

For playback:

7. Connect the **EXT SYNC OUT** jack to the input of the external device. To start with, set the **EXT SYNC OUT LEVEL** to the "3 o'clock" position (a quarter turn below full output).
8. Press **PLAY**. When tape reaches the start point, the sequencer should start.

If you experience miscueing or problems (especially while overdubbing onto track 3), try this trick: turn down the **EXT SYNC OUT LEVEL** control until the sequencer stops playing. Then turn it back up until it resumes, and a little past that point. By turning down the **SYNC OUT LEVEL**, you are also turning down any other interference that may be going out the jack, putting it below where the external sync unit can be confused by it.

SYNCHRONIZING THE 644 TO ANOTHER TAPE DECK

Machine synchronization is much more complicated than MIDI synchronization. MIDI is done electronically, while synchronizing two tape machines together involves motors, inertia, and other factors in addition to electronics.

It also involves SMPTE Time Code, an audio tone recorded on a track of the recorder the same way that MTS sync tone is. But instead of MIDI clocks and Song Pointer, SMPTE time code continuously issues the time in hours, minutes, seconds, and frames. A synchronizer reads this time code from two tape machines at once, then issues commands to the slave machine that cause it to "chase-lock" with the master machine.

The 644 Midistudio is equipped with a serial interface port (**ACCESSORY 2**) that allows it to be either master or slave when connected to the **TASCAM MIDIIZER** or other synchronizers that support the **TASCAM** serial

interface standard. A complete explanation of procedures will be found in the manual for your synchronizer but here are a few notes about recording and playing back SMPTE that you must know.

Recording SMPTE Time Code

1. Take the **TIME CODE GENERATOR OUT** of the synchronizer and plug it into the **EXT SYNC IN** jack of the 644.
2. Set the **SYNC** switch on the 644 to **EXT**. The yellow LED will turn on.
3. Turn the **RECORD FUNCTION** for Track 4 on.
4. Set the **DISPLAY** to **OUTPUT** so you can see the tape level.
5. Set the **EXT SYNC IN LEVEL** control until Group 4's meter reads 0 dB. Alternatively, the time code generator may have its own output level control.
6. Press **RECORD** and **PLAY**. Press **START** on the time code generator.

For playback:

7. Connect the **EXT SYNC OUT** jack to the **Time Code input (either Master or Slave)** of the synchronizer. To start with, set the **EXT SYNC OUT LEVEL** to the "3 o'clock" position (a quarter turn below full output).
8. Press **PLAY**. The time code display on the synchronizer or reader should increment. To verify that the machine is getting time code (and not counting tach pulses), temporarily unplug the **ACCESSORY 2** jack from the 644. If the reader still is running, and it stops and starts as you stop and play the 644, you've successfully recorded SMPTE.

MIDI Automation Section

In addition to the MIDI Sync capabilities, the 644 also provides access to functions which are achieved relying on MIDI Program Change and Note On/Off commands. You don't have to use any of them if you don't want to. But you should be aware of the possibilities. More specifically you can:

- Use an "UP/DOWN" footswitch to issue Program Change Commands to your MIDI instruments from the 644
- Send Program Change commands from a MIDI keyboard or other controller to change scene numbers of the 644
- Use note commands from a keyboard or sequencer to individually mute and unmute the main channels of the 644
- Set the MIDI channel of the 644 so it will send and receive commands on any MIDI channel.

TRANSMITTING MIDI PROGRAM CHANGE COMMANDS FROM THE 644

Hookup

1. Connect a MIDI cable from one of the **MIDI OUTs** of the 644 to the **MIDI IN** of the instrument.
2. (Optional) Connect the **RC-60P** footswitch to the **REMOTE UP/DOWN** jack of the 644. (Otherwise, you can use the 10-number keys or the **UP**, **DOWN** keys directly on the 644).

Setting the MIDI Channel

3. Press the **SCENE/MIDI CH** key until the **MIDI CH** indicator appears above the scene number. Now the number display will show the current MIDI send and receive channel: (omni) **ON**, 1-16, or **OFF** (off, which makes the 644 ignore all PC and note on/off messages).

Continued on page 44

MIXER SECTION

1. MIC TRIM: This sets how much preamplification level there is on the MIC Input only; it doesn't affect the LINE or TAPE inputs. The MIC TRIM should be set high enough to amplify the source above the noise floor of the electronics, but not so high that it distorts the sound of the mixer. When the MIC TRIM is turned all the way to the left, no gain is added to the signal, and it can be used as a LINE A jack. Use this setting whenever you have a high-level source (such as a synthesizer) connected to the top MIC/LINE A jack. When the MIC TRIM is turned full clockwise the signal at the MIC jack will be amplified 40 dB, which is needed by low-level microphone sources. You can determine the proper MIC TRIM level for your application with the help of the INPUT METER. After the mic level has been set with the MIC TRIM control, signal goes to the scene display, where MIC INPUT can be chosen for any MAIN or DUAL channel path.

2. Equalizer: The three-band with midrange sweep equalizer allows you to adjust the tonality of the signal going through the MAIN channel only. It gets its signal from the MAIN INPUT switch, and sends it to the MAIN CHANNEL FADER via the INSERT jack. HIGH is a treble shelving-type control with a hinge point of 10 kHz, which can affect signals from 20 kHz down to 5 kHz. The MID section is a peak-and-dip sweep type, with two controls: the SWEEP control allows you to select the specific frequency range you want to affect (centered from 250 Hz, upper bass, to 5 kHz,

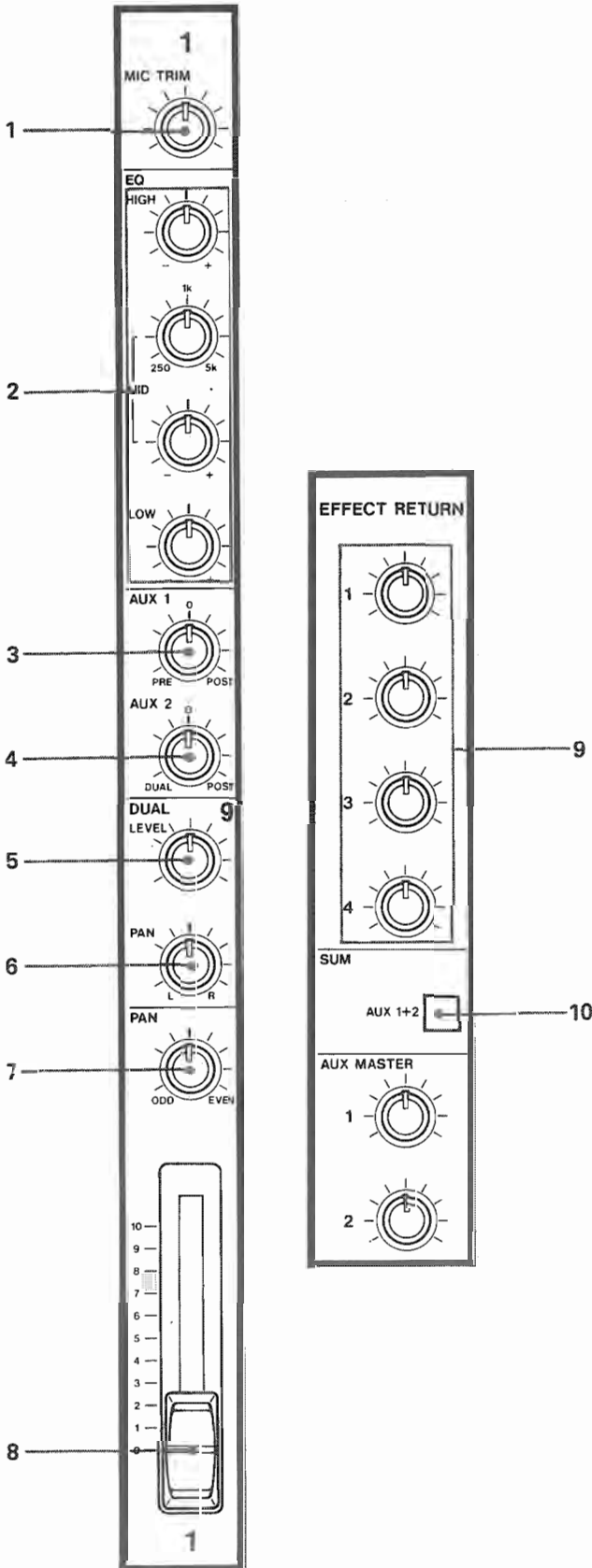
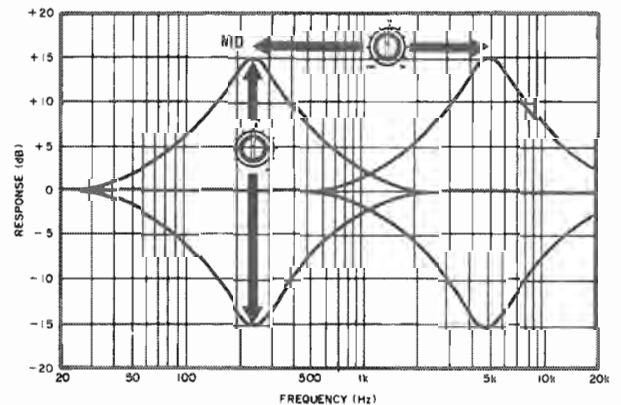
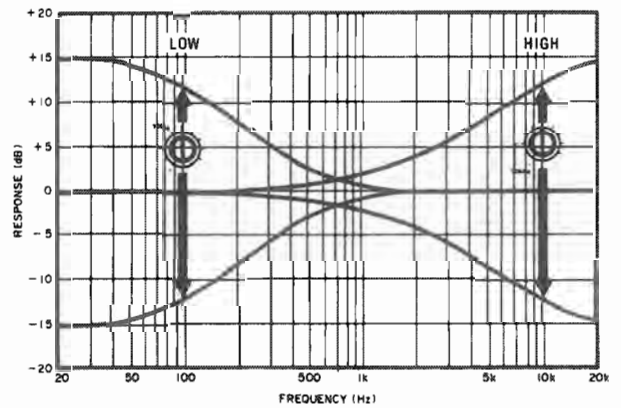

low treble), while the MID LEVEL controls whether that frequency band will be increased or decreased. LOW is a bass shelving control, with a hinge point of 100 Hz, that can affect signals from 20 Hz up to 250 Hz. HIGH, MID and LOW level controls work similarly to the controls on other audio equipment: turn to the right of center to boost, to the left of center to cut, or leave in the center for no effect (flat response).

3. AUX 1: This is a combination "where from" and "how much" control. It typically controls how much signal will go to an external effects device or headphone mix. It gets its signal from a point just before (PRE) or after (POST) the MAIN CHANNEL FADER. It sends signal down the AUX 1 buss to AUX MASTER 1.

Unlike most "effects" sends, the OFF position of the AUX 1 knob is the center detent (12 o'clock). Turn to the right of center to send signal to AUX 1 from the POST-fader point, or to the left of center to send signal to AUX 1 from the PRE-fader point. The farther you turn it either way, the louder it will be—if it's turned all the way to the left, it's at full volume.

POST means that when you change the level on the MAIN CHANNEL FADER the AUX 1 send will also change. Use POST if AUX 1 is connected to an effects unit, because when you fade out a signal you (usually) don't want its reverb to stay in the mix. PRE means that AUX 1 will not be affected by changes to the MAIN CHANNEL FADER. This is useful when AUX 1 is used as a performer's headphone mix, because once you've got their mix set, you don't want it to change as you adjust the mix feeding the tape recorder. In PA applications, this is called a "monitor" or "cue" control. See p. 19, "Using Effects".

4. AUX 2: This controls how much signal is sent to the AUX 2 MASTER and output jack. It is typically used to send a mix to a second external effects device (such as a reverb). It works the same way as AUX 1 (above) with one important exception: when you turn it to the left of center, AUX 2 will get its signal from a point after the DUAL LEVEL control. The most common use for AUX 2 is as the effects send for the dual section (channels 9-16). Turning it to the right (POST) gives you the same POST-MAIN FADER signal that appears at AUX 1's POST, in case you want to have two different effects on the MAIN input. See p. 19, "Using Effects".

5. DUAL LEVEL: This controls how much of the signal chosen by the DUAL INPUT on the scene display (either MIC, LINE, TAPE or POST) goes to the DUAL PAN just below it, and then on to the DUAL MASTER stereo output. The Dual section is usually used for tape monitoring during tracking and overdubbing, but can also be used for eight additional inputs to the main mix, or as a stereo effects send from the main channels.

6. DUAL PAN: This control allows you to create stereo mixes by sending the DUAL input in continuously variable degrees anywhere to the left or right of the stereo DUAL OUTPUT. It gets its signal from the DUAL LEVEL and sends it down the dual L/R busses to the DUAL MASTER control.

7. PAN (Main): This control allows you to create stereo mixes by sending the MAIN input in continuously variable degrees anywhere to the left or right sides of the main mix: pan left to feed ASSIGN GROUPS 1 and 3, pan right to feed ASSIGN GROUPS 2 and 4. Between "hard left" and "hard right" settings, signal is available (in differing degrees) to all four groups. The PAN gets its signal from the MAIN CHANNEL FADER and sends it to the ASSIGN GROUP electronic switches controlled by the scene display. A PAN control is a combination "where to/how much" control, in that it controls both the level and direction of a signal. Note that even if a channel is assigned to a group, if the PAN is set all the way to the other side, no signal will get through to that group.

8. Main Channel Fader: This linear slide fader varies the level feeding the PAN control and GROUP ASSIGN switches, the POST side of AUX 1 & 2, and the POST position of the DUAL INPUT switch. The fader is set for unity gain (level in=level out) in the middle of the shaded area between 7 and 8.

9. EFFECT RETURNS 1-4: These control set how much signal is sent from the four EFFECT RETURN JACKS to the EFFECT ASSIGN screen display, where any effect return may be assigned to any group. Once an effects return is assigned to a group, it goes to the GROUP MASTER FADER to be mixed along with the main signals to be recorded.

A special feature of the effect returns is for those who use mono effect returns. If a signal (for example, the output of a reverb) is plugged into return #1, but there is nothing plugged into return #2, the reverb signal will go to both EFFECT RETURN 1 and EFFECT RETURN 2 controls. By assigning each RETURN to a different group, you can vary the two controls to send signal anywhere between the two groups, similar to using a pan pot. EFFECT RETURNS 3 and 4 work the same way. See p. 19, "Using Effects".

10. SUM Switch: This SUMS or combines the signal from the AUX 1 buss with the signal from the AUX 2 buss. Its main application is when you want to send signal from all 16 inputs, both MAIN 1-8 (using AUX 1) and DUAL 9-16 (using AUX 2) to the same effect unit (for example, a reverb). The SUM takes place before (pre) the AUX 1 and AUX 2 MASTER. See p. 19, "Using Effects".

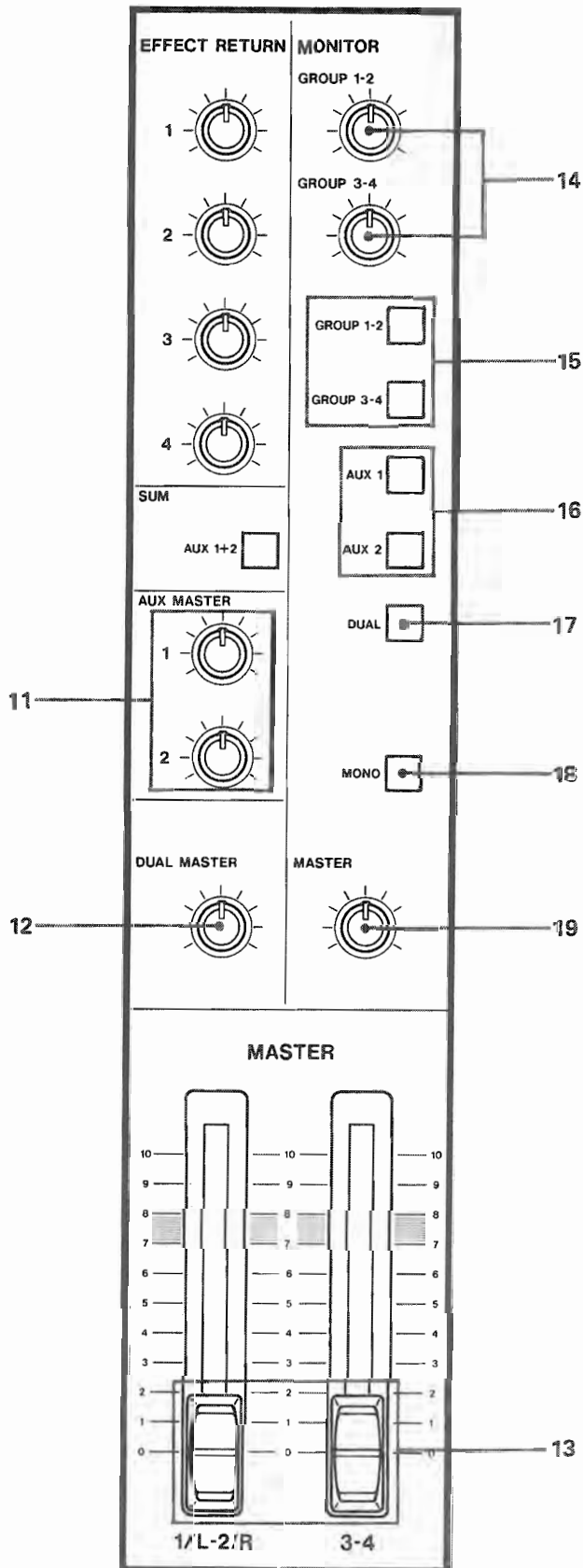

11. AUX MASTERS 1 and 2: These are the master volume controls for the AUX 1 and AUX 2 mixes. They get their signal from the AUX LEVEL controls in the channels to their left. The signal then goes to the AUX 1 and AUX 2 OUT jacks on the back panel, and the AUX 1 & 2 MONITOR SWITCHES. Adjust the AUX MASTERS until you have the correct level feeding your external effects device. See p. 20, "Setting Effects Send Levels".

12. DUAL MASTER: This is the master volume control for the DUAL stereo mix. It gets its signal from all DUAL LEVEL and PAN controls (9-16) to its left. It sends signal to the DUAL OUT L & R jacks on the back panel and to the DUAL MONITOR SWITCH and level control.

13. Group Master Faders (1/L-2/R and 3-4): These faders adjust the output levels of the groups. They get their signal from the ASSIGN GROUP switches in the routing display. They send signals to the four GROUP OUT jacks on the back panel, to the MONITOR GROUP SWITCH and LEVEL controls, and to the multitrack recorder. The left fader controls the output level of groups 1 and 2, and is labeled "L/R" because during mixdown the GROUP OUT 1/L and 2/R jacks normally feed the stereo two track recorder. The right fader controls the output levels of groups 3 and 4.

MONITOR SECTION: This section controls what you hear in your headphones or monitor speakers. It takes signals from all other mixes and allows you to hear any of them in combination. You can adjust the level you hear without disturbing the level going to the outputs or to tape.

14. GROUP 1-2 and 3-4 Levels: Adjust these rotary controls to control how much of the GROUP OUTS you'll hear in your headphone or monitor mix. Signal comes here from the GROUP MASTER FADERS, and goes to the MONITOR MASTER pot if the GROUP SWITCHES are on. Groups 1 & 3 go to the left side of the monitor, and groups 2 & 4 to the right side (unless the MONO switch is depressed). Use them when you want to hear the same mix that's feeding the recorder; for example, when you want to hear yourself play along with the track before a punch in. See p. 12, "Overdubbing" and p. 14, "Punch-in or Insert Recording".

15. GROUP 1-2 and 3-4 Switches: These are simply on-off switches between the GROUP MONITOR LEVEL controls and the MONITOR MASTER. If they're not on, turning the group level controls will have no effect.

16. AUX 1-2 Switches: These are the on-off switches between the AUX MASTER controls and the MONITOR MASTER. When they're on, they allow you to hear the mix being sent to the AUX OUT jacks. Typically they're used when you want to check the mix being sent out to a reverb unit. When either AUX is switched on alone, it can be heard through both monitor left and right (i.e., in the center); if both AUX 1 and AUX 2 switches are ON they split in stereo with AUX 1 on the left and AUX 2 on the right.

17. DUAL Switch: This is the on-off switch that brings the signal from the DUAL MASTER into the monitor mix. Since the dual section is usually used as a tape monitor mix during tracking and overdubbing, this switch is usually left on until mixdown.

18. MONO Switch: This makes the stereo monitor mix into a mono mix. There are two main applications for it. During overdubbing, many performers play better when they're listening in mono; in final mixdown, the engineer can use the MONO switch to check how the mix will sound when played back on a mono system, such as a car radio.

19. MONITOR Master: This is the overall volume control for the monitor mix. It gets its signal from the switches and controls above it, and sends it to the MONITOR OUT L/R jacks on the back panel and the PHONES jacks on the front panel, but *not* to the L-R MONITOR METERS.

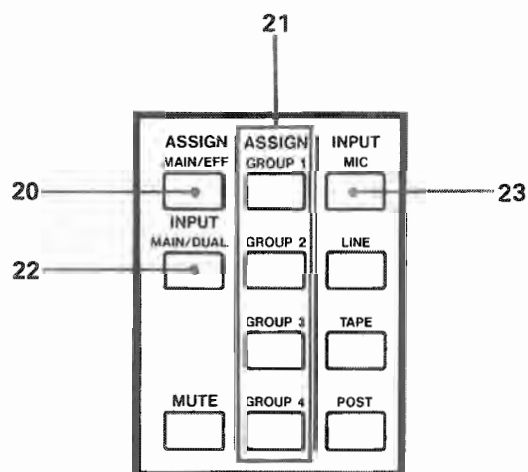

SCENE ROUTING DISPLAY AND CONTROLS

20. ASSIGN MAIN/EFF: This key switches the upper half of the scene display between two "where to" displays: ASSIGN MAIN shows the groups the 8 MAIN channels are going to, and ASSIGN EFF shows the group assignments for the 4 EFFECTS returns. Press this key to change the upper half of the display from one to the other. If you were in any previous input or assign modes, it will "disarm" them, turning off any flashing GRP or INPUT indicators. It will also switch the display out of any METER mode.

21. GROUP Keys (1, 2, 3, 4): Press any of these buttons when you want to change the main or effects ASSIGN settings. The GRP indicator(s) will start flashing and any MUTE or INPUT indicators that had been flashing will stop. While any GRP indicator is flashing, press any of the eight CHANNEL keys to send (assign) a channel's signal to the group output(s). Pressing the CHANNEL key again will turn that group off.

The ASSIGN MAIN switch of a channel gets its signal from the lower PAN control, and sends it to the GROUP MASTER FADER. Note that if a channel's pan pot is turned all the way to the right, no signal will go to group 1 or 3 even if the channel is assigned to those groups. The ASSIGN EFF switches get their signals from the EFFECT RETURN level controls, and also send it on to the GROUP MASTER FADERS.

Each GROUP is a mix that goes through a MASTER FADER, and then feeds: 1. the multitrack tape, 2. a GROUP OUT jack on the back panel, 3. the GROUP OUTPUT METER, and 4. the MONITOR switch and level pot. At mixdown, Groups 1 and 2 are usually used to feed a 2-track recorder with the final stereo mix. See p. 5, "Tracking, Overdubbing, and Mixing".

22. INPUT MAIN/DUAL: There are two "where from" displays: one for the MAIN channels (1-8) and another for the DUAL channels (9-16). They allow you to see and change the source of each channel. Press this button to change the lower half of the display from one to the other. It also clears any flashing (selected) input or group mode. The next step is to "arm" one of the following four input modes:

23. MIC: Press this key to enter MIC INPUT mode (and automatically leave ASSIGN, MUTE or any other INPUT mode). While the MIC indicator is flashing, press any of the eight CHANNEL keys to select the microphone jack as a source for that channel. Pressing the CHANNEL key again turns the mic selection off. (The mic signal passes through a preamp and the MIC TRIM control at all times.)

If MAIN is lit in the INPUT display, you will be choosing MIC as the source for a main channel (1-8), sending it through the equalizer, insert point, and MAIN CHANNEL FADER. If DUAL is lit, you will be choosing MIC as the source for a dual channel (9-16), sending it to the DUAL LEVEL control. Press the MAIN/DUAL switch to toggle between the two screens.

Typically, you'll route mics through the main channel path so they can be equalized, compressed (via the insert jack) and sent to the multitrack recorder via the groups.

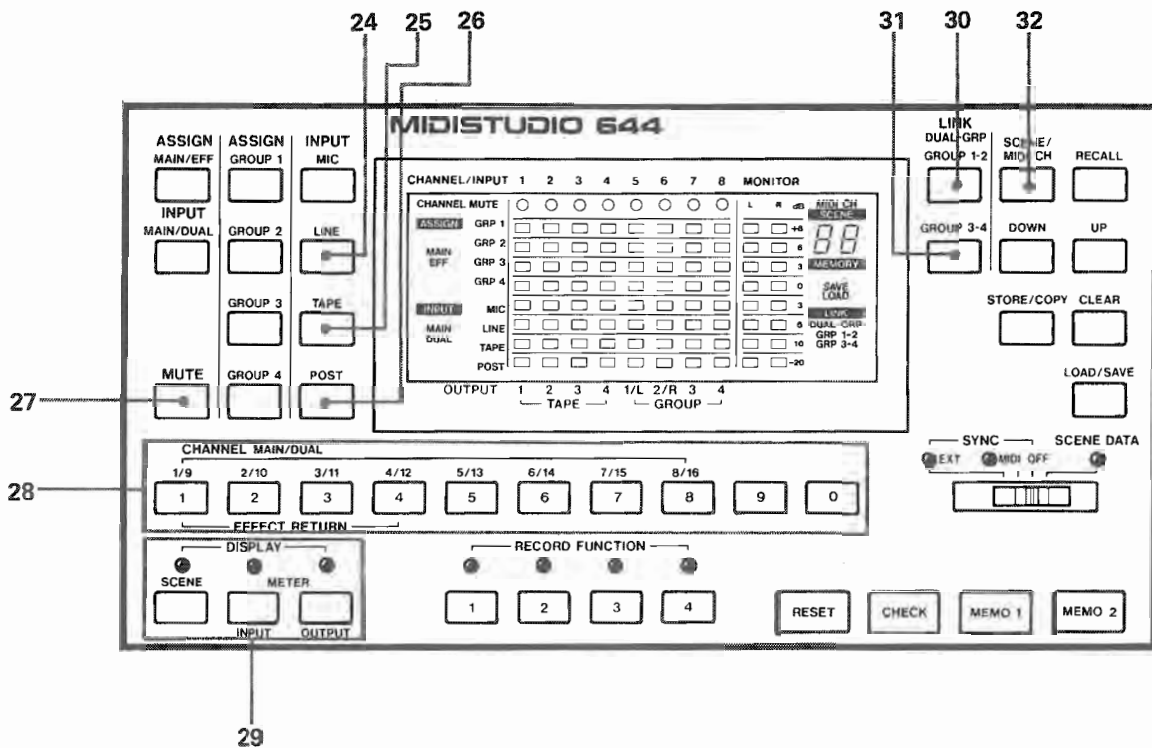

24. LINE: Press this button to enter LINE INPUT mode (and automatically leave ASSIGN, MUTE or any other INPUT mode). While the LINE indicator is flashing, press any of the eight CHANNEL keys to select the line jack as a source for that channel. Pressing the CHANNEL key again will turn the line selection off.

If MAIN is lit in the INPUT display, you will be choosing line as the source for a MAIN channel (1-8). If DUAL is lit, you will be choosing line as the source for a DUAL channel (9-16). Press the MAIN/DUAL switch to toggle between the two screens.

Typically, you'll bring a LINE input to the main mix if it needs EQ, or it needs to be recorded onto multitrack. Bring a line input to the dual mix if it's MIDI controlled and you want to monitor it but not record it until mixdown.

25. TAPE: Press this button to enter TAPE INPUT mode (and automatically leave ASSIGN, MUTE or any other INPUT mode). While TAPE indicator is flashing, press any of the first four CHANNEL keys to select the output of the multitrack tape as the input source for that channel. Pressing the CHANNEL key again will turn the tape selection off. Pressing CHANNEL keys 5-8 will have no effect, because there are only 4 tape tracks.

If MAIN is lit in the INPUT display, you will be choosing tape as the source for a main channel (1-4). This is the route usually taken during mixdown or bouncing tracks (see p. 12). If DUAL is lit, you will be choosing tape as the source for a dual channel (9-16), which

is the usual monitoring position during tracking and overdubbing. Press the MAIN/DUAL switch to toggle between the two screens.

26. POST: This key has no effect unless you are in DUAL INPUT mode, since only the DUAL channels can be put into POST. Press the MAIN/DUAL switch so that DUAL is lit under INPUT. Press the POST button to enter POST INPUT mode (and automatically leave ASSIGN, MUTE or any other INPUT mode). While the POST indicator is flashing, press any of the eight CHANNEL keys to select the post-fader main signal as the source for the DUAL control just above it. Pressing the CHANNEL key again will turn the post selection off.

POST is usually used when you want the DUAL to act as an effects send, similar to the way the AUX 1 and AUX 2 pots work when you turn their pots to the right. When POST is on, the DUAL pots lose their independence; so instead of thinking of them as channels 9-16, they become "AUX 3-4" from the MAIN channels 1-8. When you bring down fader 1, the signal to the DUAL 9 pot will go down in proportion, because it's getting its signal from a point after the main fader. See p 21, "Dual as an Effect Send".

27. MUTE: Press this button to enter CHANNEL MUTE mode (and automatically leave ASSIGN or INPUT mode). When the CHANNEL MUTE indicator is flashing, press any CHANNEL key to mute that channel. The signal can't reach anywhere; it does not go to the groups nor AUXes and INSERT jack. Press the CHANNEL key again to turn the signal back on (unmute). The round dots at the top of the display show when a channel is muted. Only MAIN channels (1-8)

can be muted; the DUALS will be unaffected (unless they are in POST). You can see and edit the MUTE settings even when the display is in a METER mode. Mutes can also be turned on or off by MIDI NOTE ON/OFF commands (p. 44).

28. CHANNEL Number Keys: The ten keys underneath the LCD display numbered 1-9 and 0 serve two purposes:

Scene number keys: To go to scene 79, for example, press "7" and "9". The routing for scene 79 will appear, but the scene number is blinking to show you that the mixer isn't actually switched to scene 79 settings until you press RECALL.

Channel keys: When any of the GRP or MIC-LINE-TAPE POST indicators are flashing, the first 8 keys become CHANNEL keys, and will turn the flashing function on or off for that main or dual channel. When the ASSIGN display is in EFF, the first 4 keys become EFFECT RETURN keys, and will turn on or off the return paths to the groups.

NOTE: Pressing CLEAR will return you to the original scene display if you accidentally press the number keys and the scene number is flashing.

29. DISPLAY Key and Indicators: There are 3 possible modes for the LCD display screen:

Scene display: This is used when you want to see or edit the routing of a scene—the input selections and output assignments. The Midistudio automatically switches to scene display when any assign or input key is pressed; but this button is here so you can see the scene display without entering an edit mode.

Meter Input (1-8): This is used to check the level of signals coming into the MAIN channels 1-8. For example, if a mic is selected for channel 1, you can speak into the mic while setting the MIC TRIM control to get it as loud as possible without overloading the mixer channel, watching the input meter for reference. Note that the feed to the meter is post-EQ/pre-fader. This means you can see an input level even when it is not assigned to a group and its fader is down; and that EQ changes will affect the meter level.

Meter Output (Tape/Group 1-4): This is the most useful metering display mode because it shows you the levels coming out of the 4 mixer GROUP outputs (on the right four) and the levels of the four TAPE tracks (on the left four).

The METER OUTPUT display is the one you will probably use the most, once you understand the SCENE operation. Pressing any of the ASSIGN or INPUT keys will automatically switch the display to SCENE mode, but MUTES can be entered at any time without leaving a METER display mode.

30. LINK DUAL-GRP 1-2: Press this key to patch the stereo mix from the DUAL MASTER onto the GROUP 1-2 MASTER output, so signals from the DUAL channels can be recorded onto tracks 1 & 2 or mixed down to an external two track. The LINK DUAL-GRP indicator will light with GRP 1-2 underneath. Anything panned to the left side of the dual mix will

go to group 1, anything panned to the right will go to group 2. Press the LINE GRP 1-2 key again to disconnect the DUAL output from the groups.

31. LINK DUAL-GRP 3-4: Press this key to patch the stereo mix from the DUAL MASTER onto the GROUP 3-4 MASTER output, so they can be recorded onto tracks 3 & 4. The LINK DUAL-GRP indicator will light with GRP 3-4 underneath. Anything panned to the left side of the dual mix will go to group 3, anything panned to the right will go to group 4. Press the LINK GRP 3-4 key again to disconnect the DUAL output from the groups.

32. SCENE/MIDI CH Key: This key switches the two-digit number display between the MIDI Channel (1-16, off, or omni) and SCENE (01-99) modes. The SCENE mode is used most of the time; in this mode the scene number can be changed by UP and DOWN or by the NUMBER keys if no editing mode is armed. The display will automatically switch to SCENE if you press any channel/number, assign, or input key. MIDI CH mode is used to change the MIDI channel the Midistudio receives on; typically you'll set it one time and then leave it alone. You can only switch to MIDI CH mode if the scene number is not flashing (press CLEAR or RECALL).

The MIDI CHannel display is chosen when you want the MIDISTUDIO to change from one scene to another in response to external MIDI Program Change commands, which are transmitted on one or more of the sixteen MIDI channels. You can change the MIDI channel only with the UP or DOWN keys. In addition to the numbers 1-16 corresponding to the channels, there are two other choices: "om" and "of". "om" stands for omni mode; in this mode any Program Change command received regardless of channel will change the scene number. Omni mode is useful when you're troubleshooting a system, but not a likely choice for normal operation. "of" stands for off, which is where you should set it if you don't want the Midistudio to respond to any Program Change commands at all. See p. 44, "Changing scenes via External MIDI commands."

Note that the MIDI channel does not affect system common or system real time messages: the MIDI timing and synchronization commands (clock, Song Pointer, start/stop etc.) go through the entire system regardless of channel.

Storage function of SCENE/MIDI: When the SCENE/MIDI key is pressed while holding STORE/COPY, the current scene contents will be replaced by whatever is in the buffer memory (which is displayed when you press STORE). This STORE-SCENE is how you permanently save your edited scenes.

Clear function of SCENE/MIDI: When the SCENE/MIDI key is pressed while holding CLEAR, the current scene contents will be totally emptied—no inputs selected, no assignments, no links, no mutes. See p. 18, "Saving Scenes".

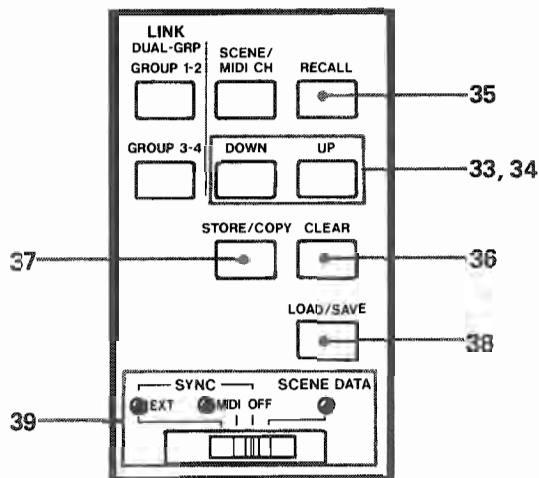

33, 34. UP and DOWN Keys: Increases or decreases the current MIDI channel or SCENE number depending on the mode (see #32). The numbers will scroll continuously if you hold the key down.

35. RECALL: Press this key to actually switch the MIDISTUDIO to the settings of a displayed scene. When the scene number is blinking, the setting shown in the display is not the current actual setting—you need to RECALL it from memory to change the settings of the electronic switches.

36. CLEAR: This key is essentially a “stop the current mode” switch—in computer use similar to an “escape” key. Press it to:

- Return the SCENE display to showing the current scene after browsing through some other ones, or accidentally hitting a NUMBER key
- Leave any ASSIGN or INPUT mode
- Abort a STORE/COPY action—turn the MEMORY display off and return to the original version of a scene
- Totally CLEAR the contents of a scene memory by holding CLEAR and pressing SCENE/MIDI CH
- CLEAR all 99 scenes, returning the first 12 to the original factory presets by holding CLEAR and turning on the power. Make sure you’ve saved any valuable scenes to tape (see p. 18, “Saving All Scenes”) before doing this.

37. STORE/COPY: This key is used when you want to store a scene to one of the 99 memory locations. Changes made with the ASSIGN and INPUT keys are temporarily held by MEMORY but need to be stored before the 644 is powered down, CLEARed, or another scene is RECALLed.

Pressing STORE places whatever routing data is in current memory (MAIN and EFF assigns, MAIN and DUAL inputs, DUAL-GRP LINKs, and CHANNEL MUTEs) into a MEMORY buffer or holding area. The MEMORY indicator appears under the scene number to show you that the data has been memorized. You can now look at other scenes until you find one that you want to replace with what’s in MEMORY.

You can press and hold STORE to compare the MEMORY buffer scene with the contents of the scene

that will be replaced. To permanently store the MEMORY buffer into a SCENE, hold STORE and press the SCENE/MIDI CH key; the MEMORY indicator will disappear. Pressing CLEAR before doing a STORE/SCENE operation will erase the contents of the memory buffer, turn off the MEMORY indicator, and return you to the original scene. See p. 18, “Saving Scenes”.

38. LOAD/SAVE: This key is active only in MIDI SYNC or SCENE DATA modes (set by the 4 position SYNC switch). Press this key to switch between SAVE or LOAD in the display under the scene number. “Save” means saving information onto tape, and “load” means loading data from the tape (track 4) into either the MIDI SYNC translator or the scene memories of the MIDISTUDIO. See p. 20, “MIDI Sync” and p. 18, “Saving All Scenes”.

39. SYNC Switch: This switch has 3 positions with accompanying LEDs, plus OFF. It directly affects the signals going to and from track 4 of the tape deck. It decides whether track 4 will be used for: a) an external sync unit, b) the internal MIDI Tape Sync, c) for normal recording, or d) to transfer the data of the 99 scenes to a backup tape.

EXT mode (yellow LED) switches the input and output of tape track 4 to the EXT SYNC jacks and level controls on the back panel. Use this when you want to use some other form of synchronization (for example, SMPTE or an FSK tone generated by the sequencer itself) instead of the internal MIDI synchronization of the MIDISTUDIO. See p. 25, “Using External Sync Devices”.

MIDI mode (red LED) dedicates track 4 to use by the internal MIDI Tape Synchronizer (MTS). This is the most common mode of operation if you use a MIDI sequencer. In MIDI SAVE mode (see “Save/Load switch” above), MIDI clocks and start-stop commands received by the Midistudio’s MIDI IN jack will be translated into a warbling tone called an FSK signal that can be recorded on Track 4. In LOAD mode this FSK signal is sent from track 4’s output directly to the input of the MTS, which translates it back into MIDI signals for the MIDI OUT jack, where it can be connected to sequencers or rhythm machines to follow in perfect synchronization with the tape.

OFF mode is the only way to get conventional audio signals onto track 4 from GROUP 4 of the mixer. This is the mode to use if you are not using any MIDI or SMPTE synchronization.

DATA mode (red LED) is used to save SCENE data onto a cassette tape. In SAVE DATA mode, the settings of all 99 scenes are changed into a computerized tone that you record on track 4 of a cassette. Later, if you have edited scenes and want to return the Midistudio’s memory to its previous version, you get the cassette and go through the DATA LOAD operation. In both cases, you will see the SCENE number increase about every second; a complete save or load operation takes a few minutes. There is no way to save or load individual scenes; DATA takes a “snapshot” of the entire memory.

RECORDER SECTION

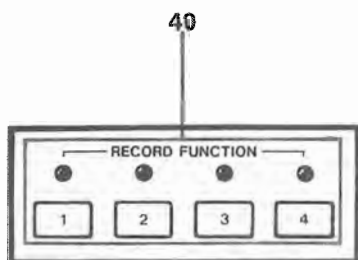

40. RECORD FUNCTION Buttons and LEDs: Pressing any of these eight buttons puts the corresponding track into Record-Ready mode, or directly into Record mode if RECORD (●) and PLAY (▶) have already been pressed.

Functions of the RECORD FUNCTION LED:

- A) LED off Safe: recording cannot occur on that track.
- B) LED blinking Record-Ready: recording on that track will occur when RECORD and PLAY are pressed.
- C) LED on solid Recording on that track is in progress (RHSL or actual) or, if RECORD and PLAY were PAUSED, recording will resume when PLAY is pressed.

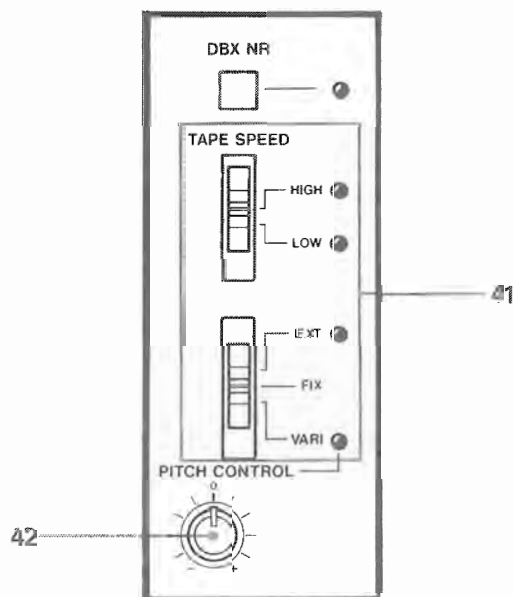

41. TAPE SPEED Switches: The lower three position switch controls the status of the PITCH CONTROL function. In the FIX position, the PITCH CONTROL will be locked off and the tape will run at 4.75 cm/sec. (1-7/8 ips) or 9.5 cm/sec. (3-3/4 ips) as selected by the upper HIGH/LOW switch. In the VARI position, the PITCH CONTROL will function and an LED will indicate that it is on. In the EXT position, the transport speed of the recorder will be controlled by a device plugged into the SERIAL connector on the back panel. SMPTE Controllers and Synchronizers will normally be used with this function. The yellow LED for EXT will light steadily, indicating that the capstan motor is under control of a DC 5 V reference signal coming from the exterior. Interruption of this external signal will cause the LED to blink.

42. PITCH CONTROL: This knob allows you to adjust the speed of the 644 by plus or minus 12% (approx.) in either PLAY or RECORD. You can use this speed control to accommodate minor changes necessary in the length or relative pitch of your program material. If you're making a 30 second radio commercial and it runs a little long, you can speed it up enough to drop out the extra seconds. When tape runs faster than the speed at which it was recorded, the material on it will raise in pitch. This can sometimes be used in a creative way to same parts that are a little out-of-tune, or to create sound effects such as flanging. If you record with the PITCH CONTROL at its maximum or minimum settings, you will NOT have the ability to make further adjustment in that direction upon playback.

Also, it is recommended that you run the 644 for several seconds in the play mode for the speed to stabilize, especially when the change in speed is large. Before beginning to record again, check the pitch carefully with a short playback, and you will have less trouble with drift.

CAUTION: The PITCH CONTROL affects the record speed also. Check to make sure that the TAPE SPEED select switch is set to FIX unless you are using the PITCH CONTROL intentionally.

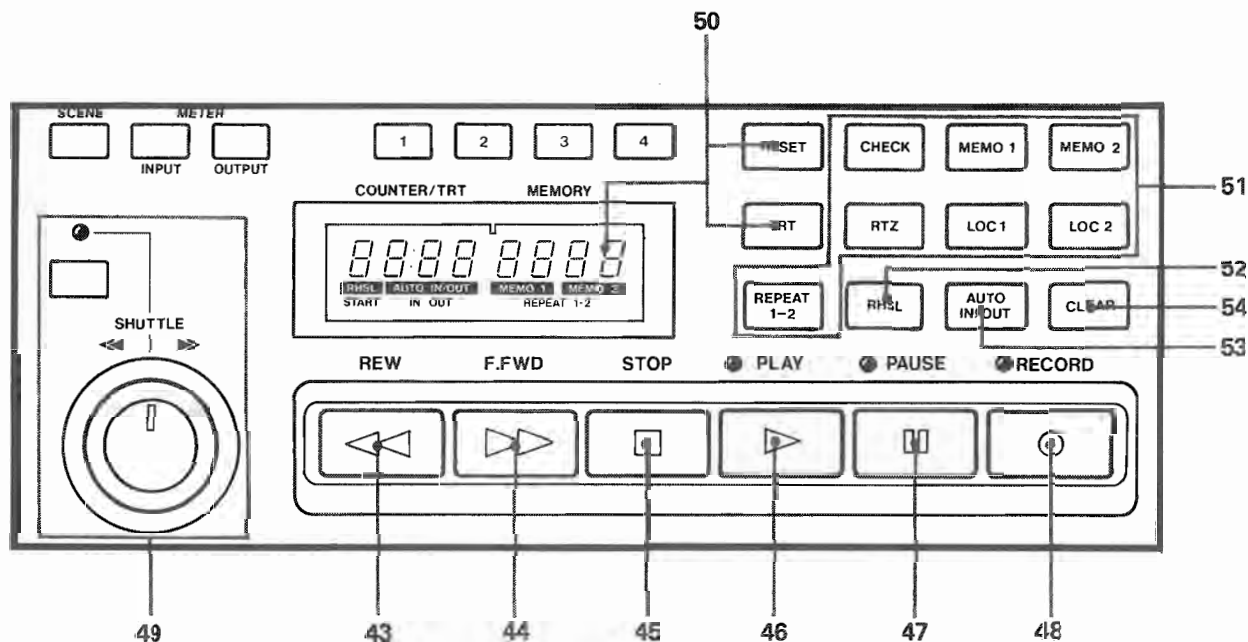

43. REW (◀◀) Button: Winds the tape at high speed in reverse.

44. F.FWD (▶▶) Button: Winds the tape at high speed in the forward direction.

45. STOP (■) Button: Stops any tape motion.

46. PLAY (▶) Button

a) Pressing this button alone starts tape playback (the green LED above the button will turn on).

b) If pressed during Record/Pause, the PLAY button resumes recording (green LED stays ON).

c) Pressing the button during recording stops the recording without stopping the tape motion ("PUNCH OUT" function occurs and green LED stays ON)

d) If PLAY is pressed after LOC, RTZ or REW, the transport will automatically enter Play mode as soon as the memory points or tape end is reached.

47. PAUSE (||) Button: Pressing this button in record or play mode retracts the pinch roller from the capstan and temporarily stops the tape. However, the previously selected mode is retained, and pressing PLAY (▶) button will resume record or play accordingly. A red LED will light above the PAUSE button when the 644 is in PAUSE mode.

If PAUSE is pressed after LOC, RTZ or REW, the transport will automatically enter Pause mode as soon as the memory points or tape end is reached.

48. RECORD (●) Button: Pressing this button alone has no effect. Pressing it together with PLAY (▶) carries two functions:

1) If any RECORD FUNCTION switches are engaged, the LEDs above them as well as the RECORD LED will stay on, and recording will begin on the corresponding tracks.

2) If none of the RECORD FUNCTION switches is engaged, the RECORD LED will blink to indicate a record ready.

The RECORD LED conveys the following messages:

A) LED out: safe mode – no recording is taking place.

B) LED blinking: record ready mode – tape is rolling at play speed (green PLAY LED on), but not actual recording is in progress. Recording will start as soon as any RECORD FUNCTION switch or switches are pressed on.

C) LED steadily on: record or record/pause – recording is taking place unless PAUSE (||) button is engaged and the red LED above the button lights up. When the transport is in Pause mode, pressing PLAY (▶) will start or resume recording.

49. SHUTTLE Button and Control Knob

When the SHUTTLE button is pressed, the red LED above the button will light, and the knob beneath can be used to roll tape forward or in reverse as you monitor its playback, at continuously variable speeds determined by the amount of knob rotation.

The further the knob is rotated clockwise, the faster the tape will roll in the forward direction (toward the right). Conversely, as the knob is rotated counterclockwise, the tape will roll backward (toward the left).

Returning the knob to its original, centered position will stop the tape.

Pressing STOP or any other transport control buttons will disable the SHUTTLE function.

CAUTION: Extensive use of the SHUTTLE causes premature wearing of the heads. Use the SHUTTLE sparingly!

50. COUNTER Display with the RESET and TRT Switches: (As for the MEMORY display, refer to #51 and 52.) The 4-digit COUNTER display has a double function:

- 1) When the 644 is first turned on, the COUNTER switches to its normal tape counter mode and displays "0000" (not 00:00).
- 2) Pressing the "TRT" (Tape Run Time) button switches the display from COUNTER mode to Tape Run Time mode, as indicated by a colon ":" in the window.
- 3) The maximum readout time is 59 minutes, 59 seconds (displayed as 59:59).
- 4) Unlike the normal Tape Counter mode which counts tape motion in both forward (RECORD, PLAY and FAST FORWARD modes) and reverse (REWIND mode) directions, TRT mode counts only in RECORD and PLAY.

NOTE: The TRT display is calculated from the capstan motor and will not necessarily be accurate with elapsed time as read from your wrist watch or wall clock.

- 5) Both the Tape Counter and TRT modes are active at the same time. Therefore, switching the display from one mode to another does not disable or reset the previously displayed readout. You can switch COUNTER display modes as often as needed and the readouts will not be cancelled or reset to 0000.

The RESET switch has effect only on the currently displayed readout. When the 644 is turned off, both the displayed and hidden readouts are reset.

The current tape location readouts (displayed or hidden) can be put into memory system of the 644. See the next item, #51.

51. Autolocator Section: Grouped to this section are the following:

- 1) MEMO 1 and 2
- 2) CHECK
- 3) LOC 1 and 2
- 4) RTZ
- 5) REPEAT

MEMO 1 and MEMO 2: These buttons are used to establish 2 autolocation points in the 644's memory system. They can be used while the tape is stopped or rolling. Pressing either button at any point on the tape loads the current tape counter number into that memory register and into the MEMORY display. Each time the button is pressed, a new MEMO point is established, erasing all previous memories in that register. "MEMO 1" or "MEMO 2" will light in the MEMORY window to show which location is currently being displayed. Both MEMO points are erased when power is turned off or when a cassette tape is ejected.

The MEMO points will not move even if the Zero position is changed by the RESET button. For example, if MEMO 1 is pressed at counter 0155 and RESET is afterwards pressed at 0150, then the 644's memory system will calculate where the 0155 point is with respect to the New Zero position and display the MEMO 1 point as 0005.

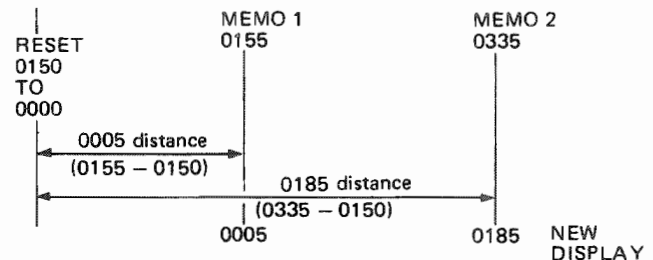

The MEMO points are based on the counter readouts and the counter is based on revolutions of the cassette hub. The MEMO points are subject to variations in tape pack. Slight drifting of a cue point after a number of fast wind operations is normal.

CHECK: The CHECK button toggles the MEMORY display between the contents of MEMO 1 and MEMO 2. The corresponding indicators will light to show which one is being displayed.

LOC 1 and LOC 2: Pressing either of these buttons causes the tape to roll (in either F.FWD or REW) to the corresponding MEMO point. While fast winding, the MEMO number will flash in the display. The tape will stop when it reaches the MEMO point. If PLAY is pressed while the tape is locating, the 644 will automatically enter Play mode after reaching the memorized point.

When the tape overshoots the memorized point, it will roll back at Slow Play speed, stopping at, or if PLAY has been pressed, starting playback from the memorized point. Don't hit PLAY during that Slow Play interim.

If so, the tape may be blocked. If this happens by accident, defeat it by pressing STOP.

RTZ (Return to Zero): Pressing the RTZ button will cause the 644 to fast wind (FAST FORWARD or REWIND) the tape to the COUNTER 0000 point on the tape.

REPEAT: The REPEAT function provides a "Playback Loop" or "Block Repeat" between the two programmed MEMO points. Note that MEMO 2 does NOT have to be a number greater than MEMO 1. When REPEAT is enabled and the current counter number is between the two MEMO points, the tape will play to the higher MEMO location, rewind to the lower MEMO location and start over. This cycle will repeat until STOP, or any other transport button is pressed.

During REPEAT all the transport buttons are active: If you rewind the tape out of the loop and then press PLAY, the tape will normally start playing, and when the loop end is reached the tape will rewind to the start point to resume the repeat. If you fast-forward the tape out of the loop, the REPEAT indicator will blink showing that if you want to resume the repeat you have to rewind back to a point within the loop or a point lower than the START point.

Unless REPEAT is again pressed the function continues to be active.

52. RHSL (Rehearsal) Button: RHSL is the first stage of an automatic punch-in recording. During Rehearsal Set mode ("RHSL" blinking in the display), the 644 memorizes the preroll, punch-in and punch-out counter locations that are used for rehearsals and for AUTO IN/OUT.

In Rehearsal mode, the RHSL function switches the output of tracks in record ready mode from tape to source and back again at the preset points but no signal will be recorded to tape. This allows you to hear what a punch-in will sound like before you actually record it, without having to manually press any keys or footswitch.

When the RHSL indicator is on solid, the 644 is in RHSL Ready mode, and pressing PLAY (▶) will start a rehearsal loop.

The MEMORY display will read out the following messages as you go through the Rehearsal Set operations (RHSL indicator on solid).

- 1) "START xxxx" appears as you press PLAY (▶) and the 644 will start the pre-roll.
- 2) "IN xxxx" appears as you press RECORD (■). This loads the 644's memory with the Punch-in point.
- 3) "OUT xxxx" appears as you press PLAY again. This loads the 644's memory with the Punch-out point.
- 4) After a 3-second postroll, the tape will automatically rewind to the START point. While rewinding, the START number will flash in the display. Pressing PLAY will start the rehearsal loop. (You can press AUTO then PLAY to start the actual recording

without passing through any rehearsal. But, pressing AUTO before setting all the three points, START, IN and OUT, will cause nothing to occur.)

As you go through the Rehearsal loop ("RHSL" on solid), the MEMORY display will let you know the upcoming IN and OUT locations as follows:

- 1) The display number changes to show the IN point as you press PLAY to start the preroll.
- 2) The display number changes to show the OUT point as you reach the IN point. At the same time, the indication "START" changes to "IN".
- 3) The indication "IN" changes to "OUT" as you reach the OUT point. The display number does not change and continues to show the OUT point until you reach the loop end.

53. AUTO IN/OUT Button: After you have set the tape's pre-roll START point, the Punch-IN and Punch-OUT points in RHSL mode, entering the 644's AUTO IN/OUT mode puts it into a ready state to commit the record Punch to tape.

- Pressing this button puts the 644 into its automatic Punch-in/Punch-Out mode.
- Pressing PLAY (▶) or the RC-30P footswitch initiates the actual recording by activating the automatic Punch-In/Punch-Out sequence (Pre-roll, Punch-In, Punch-Out and Post-roll).

54. CLEAR Button: This button is used to turn off the RHSL and AUTO IN/OUT functions. If CLEAR is pressed while the 644 is in RHSL or AUTO IN/OUT, the 644 will turn off the current mode and return to normal operation. Pressing CLEAR during any other modes has no effect.

BACK PANEL

55. GROUP OUT Jacks 1-4: These jacks are the outputs of the mixer section of the Midistudio. Signal comes to these jacks directly after the two GROUP MASTER FADERS. The 1/L and 2/R jacks are typically connected to your two-track mastering recorder at mix-down. Another use of the GROUP OUT jacks is when you want to send the mixer outputs of the Midistudio to the sub inputs of a larger console.

56. TAPE OUT Jacks 1-4: These jacks are the outputs of the multitrack recorder of the Midistudio. Use them if you want to mix the tape down with an external mixing console, or if you want to make a backup copy of your master 4-track onto another tape deck.

57. MIC (LINE A) 1/9-8/16: These 1/4" phone connectors will accept unbalanced low-level signals from almost any type of microphone with an impedance of 150 to 10,000 ohms. They are also used for instruments with low output levels that need preamplification, such as guitars and basses. Higher output devices (line level, such as synthesizers) may be connected here if the MIC TRIM control is turned all the way down. Signal goes from this jack to the channel's MIC TRIM control. On channels 7/15 and 8/16, do not use the XLR jacks and the phone jacks simultaneously. If you want to use balanced microphones in inputs 1/9-6/14, you can use a simple XLR-to-1/4" adapter; alternatively use an in-line mic transformer if you need more gain or if unbalanced operation is noisy.

58. MIC (BAL) 7/15 & 8/16: These XLR connectors are the prime connection point for low-impedance balanced microphones. Pin assignment is as follows: Pin 3 is high, pin 2 is low, and Pin 1 is shield (ground). Signal feeds the channel's MIC TRIM control.

59. LINE B 1/9-8/16: These jacks are intended for line level inputs (nominal signal level of -10 dBV or 0.3 volts) such as synthesizers and audio equipment that does not need preamplification. These jacks can be connected to the MAIN and DUAL mix, depending on the settings of the ASSIGN INPUT display.

60. INSERT Jacks 1-8: The INSERT jack is a three-conductor (Tip-Ring-Sleeve or "stereo") 1/4" phone jack inserted into the MAIN channel signal path between the EQ and the channel fader. If nothing is plugged into this jack it is bypassed; but with the proper cable (a 1/4" TRS "stereo" to two 1/4" "mono" phone splitter cable, such as the TASCAM PW-2Y or PW-4Y Insertion Cable) INSERT allows you to take the preamplified signal of a MAIN channel and route it through an external signal processor (typically a compressor, limiter, or graphic equalizer). For more information, see p. 19 "Using Effects." Devices plugged into the INSERT point feed the channel fader, the PRE position of AUX 1, and the INPUT METER of that channel.

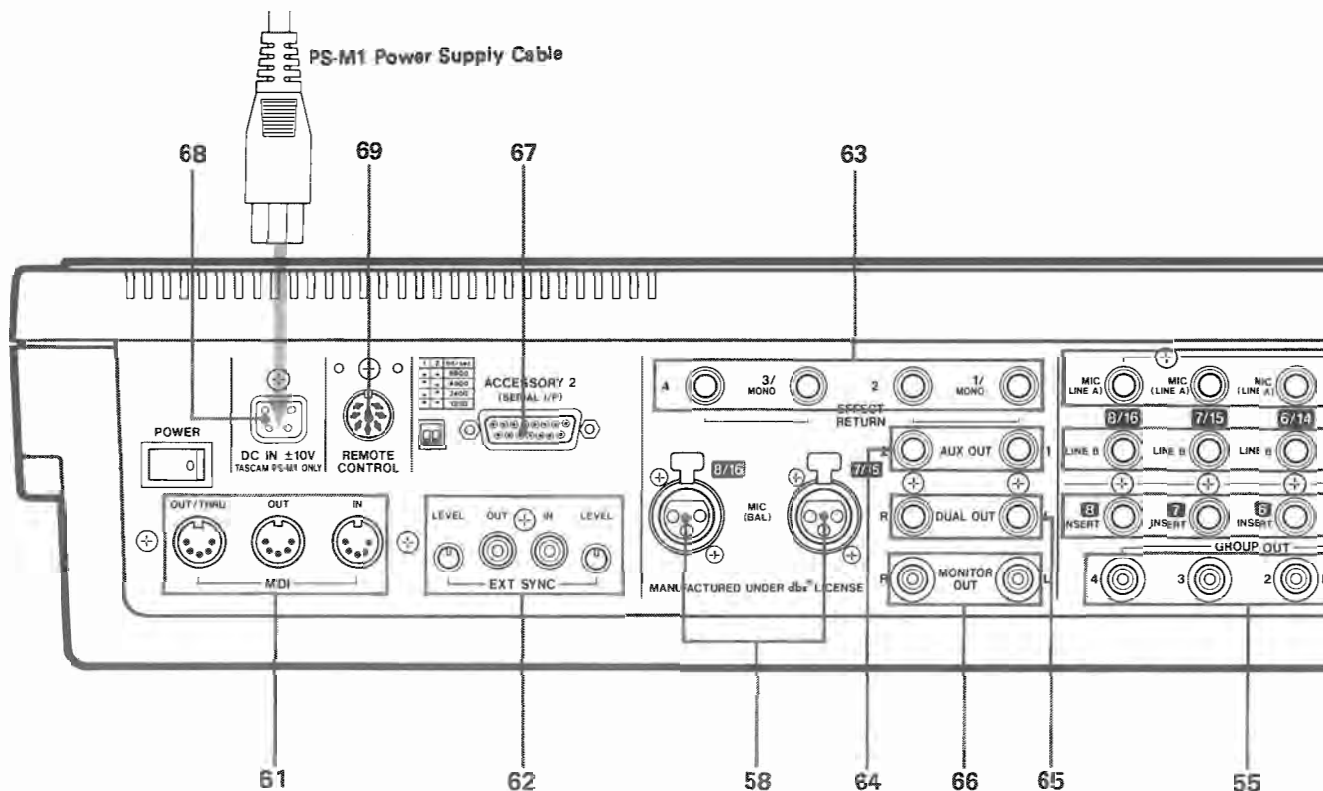

E1. MIDI Jacks: These jacks are for the connection of MIDI sequencers for synchronization to the Midistudio. They follow the MIDI specification.

MIDI IN: This jack typically accepts the MIDI OUTPUT of a sequencer. When used in MIDI SYNC SAVE mode, timing commands (start, stop, timing clocks) received by this jack will be translated and recorded onto track 4. Note that no other MIDI information (such as Channel Voice information) is recorded, although it will be "echoed" out the OUT/THRU jack in certain modes. See p. 24, "Record the MTS Sync Tone". MIDI Program Change messages received at the MIDI IN jack will change the scenes of the Midistudio, if the Midistudio is set to receive them, even in EXT SYNC or OFF modes. See p. 44, "Changing scenes via external MIDI commands."

MIDI OUT: In MIDI Sync LOAD mode, this jack sends start, stop, song position pointer, and clock to the MIDI IN of the sequencer connected to it. See p. 24, "Play back the MTS tone". Note that the Midistudio does not generate or pass any other MIDI commands (such as note on/off or program change) to this jack. During SAVE mode, the OUT jack is disconnected to prevent a signal loop from being formed.

MIDI OUT/THRU: This jack has the same output as the MIDI OUT jack except during MIDI SAVE operations, when it becomes a THRU jacks. A THRU

jack passes along information received at the IN jack, so while the Midistudio is getting the clocks from the sequencer, it passes along the note-on/off information to THRU so a synth can be heard for reference. During LOAD (playback), this jack is typically used to run a second sequencer or rhythm machine in addition to the one connected to the OUT jack.

62. EXT SYNC Jacks and LEVEL Controls: These are connected to the input and output of track 4 when the Midistudio is in EXT SYNC mode. If you are using external MIDI synchronization (such as that built-in to a sequencer), or are using SMPTE time code, connect to these jacks. The IN LEVEL should be set so that signal is recorded between -5 and 0 dB on Tape 4's meter. The OUT LEVEL should be set to match the level expected by the external device. The LEVEL controls under most conditions should be set to nominal level (2 o'clock). With certain FSK tones, lowering the OUT LEVEL will eliminate miscueing while track 3 is being recorded. See p. 25, "Using External Sync."

63. EFFECT RETURN Jacks 1-4: These jacks get signal directly to the EFFECT RETURN LEVEL knobs on the front panel. Typically, connect the outputs of your effects devices to these jacks, although you can connect any other line input if desired. Each EFFECT RETURN jack is normally independent and may be assigned to any of the group outputs via the ASSIGN EFF screen. However, if a signal (for example, the output of a reverb) is plugged into return #1, but nothing is plugged into return #2, the reverb signal will go to both EFFECT RETURN 1 and EFFECT RETURN 2 controls. Similarly, a signal patched into RETURN 3 "normals" to both the 3 & 4 LEVEL controls if there is no signal patched into RETURN 4. The input level expected by these jacks is -10 dBV (0.3 volts).

64. AUX OUT Jacks 1 & 2: These are the outputs from the AUX mixes of the Midistudio. Signal comes here directly from the AUX 1 & 2 MASTER level controls. They are typically connected to the inputs of external devices such as reverbs, digital delays, etc. They may also be used to feed a separate monitor or headphone amplifier. They provide a nominal output of -10 dBV (0.3 volts).

65. DUAL OUT L & R Jacks: Signal comes here directly from the DUAL MASTER level control. Connect here if you want to use the DUAL as a stereo effect send or additional monitor (see p. 21, "Dual as effect send"). Otherwise, these jacks are not used.

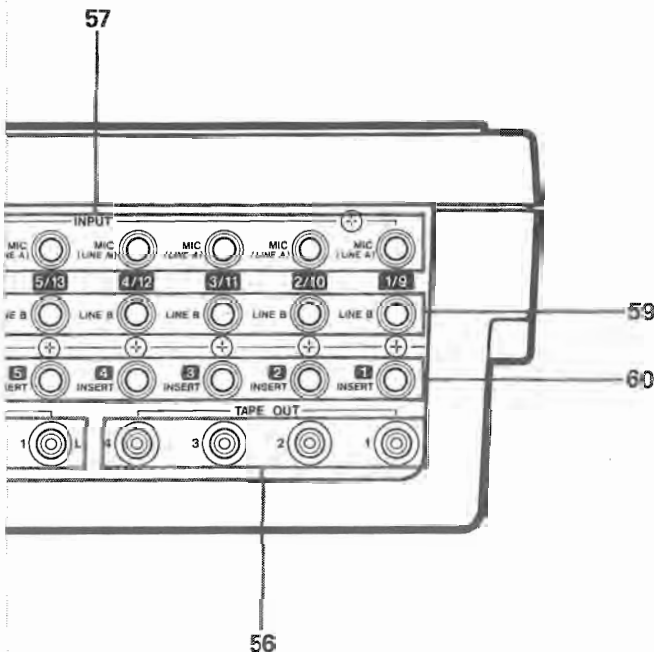

66. MONITOR OUT L & R Jacks: This is the connection point to your control room monitor amplifier; it's a line level version of the same signal that feeds the PHONES jack. Signal comes here from the MONITOR SWITCH panel and MONITOR MASTER LEVEL control, which allows these jacks to have any combination of the GROUP, AUX, or DUAL outputs as needed. The L/R meters on the right side of the display show the level of this output.

67. ACCESSORY 2, SERIAL I/F Connector (15-pin, D-SUB): This is a serial I/O port conforming to the RS-232C standard for linking the Midistudio to an external computer or serial synchronizers (such as the TASCAM MIDiiZER).

The dip switch adjacent to the D-SUB connector is used to select the bit rate as per the illustration shown below.

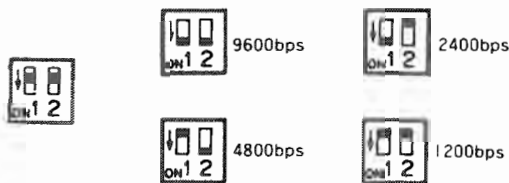

68. DC IN +/- 10V: This connector is for connection of the TASCAM PS-M1 power supply only, which provides +10 volts on one pin and -10 volts on another with a maximum current draw of 1000 milliamps. Do not use any other power supply with the Midistudio.

69. REMOTE CONTROL Jack: This is the connection point for the RC-88 remote control, which gives you remote control of all transport functions, record functions, plus rehearsal and auto record.

FRONT PANEL

70. PUNCH IN/OUT Jack: Plug the optional RC-30P footswitch in here for hands-free punch-in. In RHSL and AUTO IN/OUT modes, the footswitch will also start PLAY.

71. UP/DOWN Jack: Plug the optional RC-60P footswitch here for remote control of scene displays. It has the same effect as pressing UP or DOWN and RECALL.

72. PHONES 1/2 Jacks: Any stereo headphones with a 1/4" TRS stereo plug may be plugged into this jack. Lower impedance headphones (to 8 ohms) will be louder than high impedance (150 to 600 ohms) headphones in most cases. Do not plug a standard mono 1/4 cable into this jack under any circumstances.

"ACCESSORY 2" SERIAL CONNECTOR

The Midistudio 644 operates to its full potential when interfaced with the MIDiiZER, an intelligent, highly versatile serial synchronizer, which provides a link between SMPTE/EBU based audio/video production and MIDI music creation. It shifts between time code and MIDI data to constantly adapt the 644 and other associated machines/units to ever changing requirements of each application.

Specifically, advanced functions the MIDiiZER provides access to, include Record On/Off Programming (up to 16 individual tracks), 20-point Autolocation, Synchronization either referenced to time code addresses or MIDI coded bar numbers, Time code/MIDI data triggered events, MIDI Program Change which can be controlled with time code too, a "Total Time" function which accommodates your program material to the required length by automatically changing the tempo, and more. (Complete, update information about the MIDiiZER will be made available no later than its upcoming release.)

The method of communications performed in compliance with the RS-232C standard differ depending on the mechanical/electrical characteristics and system programs of the associated machines/devices, and a small error in communications thwarts the interfaced system and even causes this to run "wild." For detailed technical information about the use of the 644's Serial Port consult TASCAM or your local TASCAM dealer.

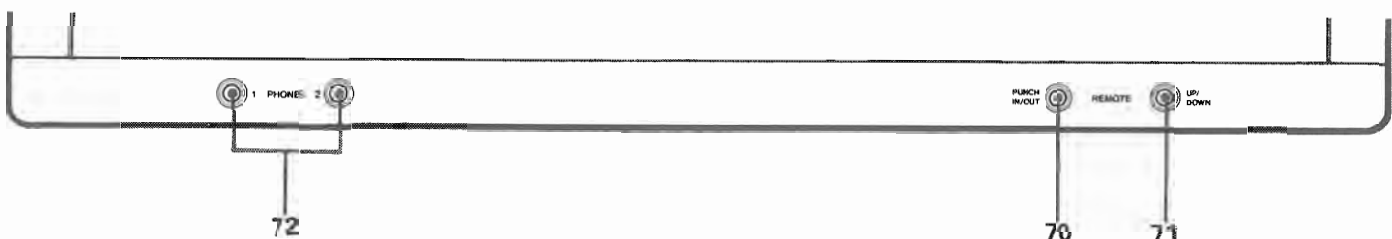

Care and Maintenance

Even though the heads used in your 644 have high wear resistance and are rigidly constructed, performance degradation or electro-mechanical failure can be prevented if maintenance is performed regularly.

CLEANING

The first things you will need for maintenance are not expensive. The whole kit with the swabs and fluids you will need for months will cost less than a couple of high quality cassettes.

We cannot stress the importance of cleaning too much. Clean up before each session. Clean up after every session. Clean up every time you take a break in the middle of a session.

Here's why:

1. Any dirt or oxide build-up on the heads will force the tape away from the gaps that record and playback. This will drastically affect the response. Even so small a layer of dirt as one thousandth of an inch will result in degraded performance. All the money you have paid for high performance will be wiped out by a bit of oxide. Wipe it off with head cleaner and you're back to normal.
2. Tape and tape oxide act very much the same way as fine sandpaper. The combination will slowly grind down the tape path. If you do not clean off this abrasive material on a regular basis, the wear will be much more rapid and will become irregular. Even wear on heads can be compensated for with electronic adjustments for a while, but uneven wear can produce notches on heads and guides that will cause the tape to "skew" and skip around, making adjustment impossible. This ragged pathway also chews up the tape, producing more abrasive material, which in turn causes more uneven wear. This begins a vicious circle that cannot be stopped once it gets a good start. The only solution to this will be to replace not only the heads, but the tape guides as well. Being conscientious about cleaning the tape path on your 644 will more than double the life of the heads and tape guides.

Cleaning the Heads and Tape Guides

All heads and metal parts in the tape path must be cleaned after every 6 hours of operation, or before starting and after ending a recording session.

1. Open the cassette door.
2. Using a good head cleaning fluid and a cotton swab, clean the heads and tape guides until the swab comes off clean. Wipe off any excess cleaning fluid with a dry swab.

Cleaning the Pinch Roller

Clean the pinch roller at least once each day the deck is used. Use a good rubber cleaner.

1. Push up the transport protection lever as illustrated. Press the PLAY button to engage the pinch roller and capstan shaft, while holding the protection lever up.
2. Lightly press a cotton swab moistened with rubber cleaner to the pinch roller on the right-hand side of the capstan shaft. This will prevent the swab from becoming entangled. Clean it until there is no visible residue on the pinch roller or coming off onto a clean swab.
3. Using a clean cotton swab, wipe off all excess rubber cleaner from the pinch roller. Make certain that there is no foreign matter remaining on either the pinch roller or the capstan shaft.

Cleaning the Capstan Shaft

After cleaning the pinch roller, clean the capstan shaft. Lightly press a cotton swab moistened with head cleaning fluid to the rotating capstan shaft.

DEGAUSSING (DEMAGNETIZING)

A little stray magnetism can become quite a big nuisance in tape recording. It only takes a small amount (.2 Gauss) to cause trouble on the record head. Playing 10 cassettes will put about that much charge on the heads. A little more than that (.7 Gauss) will start to erase high frequency signals on previously recorded tapes. You can see that it's worth taking the trouble to degauss regularly.

DEGAUSSING IS ALWAYS DONE WITH THE RECORDER TURNED OFF. If you try it with the electronics on, the current pulses produced by the degausser will look just like audio signals to the heads. These pulses are around 10,000 Gauss, and will seriously damage the electronics and/or meters. Turn off your 644, then turn on the degausser at least 1 m (3 feet) away from the recorder.

Be certain that your degausser has either a plastic cover or plastic tape covering the tip. Make sure that no metal ever touches the tape heads as it will scar them and ruin them.

Slowly move in to the tape path. Move the degausser slowly back and forth, touching lightly all metal parts in the tape path. Slowly move it away again to at least 1 m (3 feet) from the recorder before turning it off.

Be sure to concentrate while you are degaussing. Don't try to hold a conversation or think of anything else but the job you are doing. If the degausser is turned on or off by accident while it is near the heads, you may put a permanent magnetic charge on them that no amount of careful degaussing will remove. You will have to

How the dbx Works

get the heads replaced. Make sure you are wide awake for this job.

A clean and properly demagnetized tape recorder will maintain its performance without any other attention for quite a while. It won't ruin previously recorded material, nor will getting it back to original specifications be difficult.

CAUTION: If the surface of the unit gets dirty, wipe the surface with a soft cloth or use a diluted neutral cleaning fluid. Clean off thoroughly. Do not use thinner, benzine, or alcohol, as they may damage the surface of the unit.

The DBX is a wide-band compression-expansion system which provides a net noise reduction (broadband, not just hiss) of a little more than 30 dB. In addition, the compression during recording permits a net gain in tape headroom of about 10 dB.

A compression factor of 2:1 is used before recording; then, 1:2 expansion on reproduce. These compression and expansion factors are linear in decibels and allow the system to produce tape recordings with over a 90 dB dynamic range — an important feature, especially when you're making live recordings. The DBX employs RMS level sensors to eliminate compressor-expander tracking errors due to phase shifts in the tape recorder, and provides excellent transient tracking capabilities.

To achieve a large reduction in audible tape hiss, without danger of overload or high-frequency self-erasure on the tape, frequency pre-emphasis and de-emphasis are added to the signal and RMS level sensors.

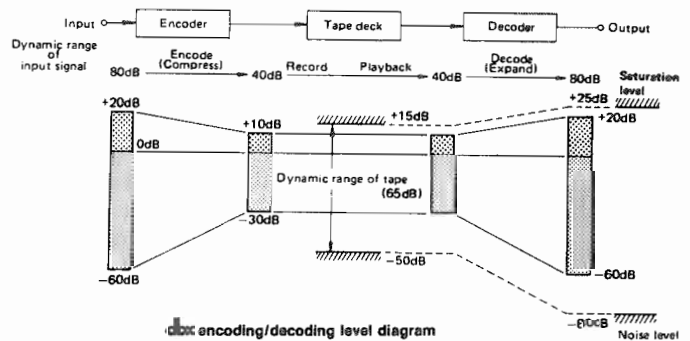

SUBSONICS AND INTERFERENCE

The DBX incorporates an effective bandpass filter. This filter suppresses undesirable subsonic frequencies to keep them from introducing errors into the encode or decode process. However, if rumble from trains or trucks is picked up by your microphone and fed to the DBX, modulation of the program material during low level passages may occur. This low-frequency component will not itself be passed through the recorder and so, will not be present at reproduce for proper decoding. If this low-level decoding error is encountered, and subsonics are suspected, we suggest the addition of a suitable high-pass filter in the Microphone Line.

4. Find out what MIDI channel your instrument is receiving on (the default setting is usually channel 1). Check the owner's manual for your instrument if you don't know how.
5. Using the UP and DOWN keys, set the MIDI channel of the 644 to the channel of your instrument.
6. Press the SCENE/MIDI CH key. The number display will go back to showing the scene number, and the MIDI CH will go out.

Check Operation

7. Press the 10-number keys or the UP/DOWN keys then RECALL or the footswitch. Your instrument should change programs at the same time the 644 changes scenes.

Note about Program Numbers

The MIDI spec calls for 128 different program change commands, 00 through 127. The 644 can transmit and receive 00 through 98. Each instrument interprets the Program Change command in its own way. Experiment with your setup and read your owner's manuals to take best advantage of the patch change feature.

CHANGING SCENES VIA EXTERNAL MIDI COMMANDS

Just as we used the 644 to send commands to the synthesizer, a synthesizer can send commands to the 644 to recall scenes.

Hookup

1. Connect a MIDI cable from the MIDI OUT of the instrument to the MIDI IN of the 644.

Setting the MIDI Channel

2. Press the SCENE/MIDI CH key until the MIDI CH indicator appears above the scene number. Now the number display will show the current MIDI send and receive channel: (omni) ON, 1-16, or OF (off, which makes the 644 ignore all PC and note on/off messages).
3. Find out what MIDI channel your instrument is transmitting on (the default setting is usually channel 1). Check the owner's manual for your instrument if you don't know how.
4. Using the UP and DOWN keys, set the MIDI channel of the 644 to the channel of your instrument.
5. Press the SCENE/MIDI CH key. The number display will go back to showing the scene number, and the MIDI CH will go out.

Check Operation

6. Press the program change key on your instrument. Your instrument should change programs at the same time the 644 changes scenes. (See "Note about Program Numbers" above).

CONTROLLING MUTES WITH NOTE MESSAGES

The 644 makes also it possible to mute individual input channels with MIDI note commands. To experiment with this, you must have a velocity-sensitive keyboard capable of sending notes 36 through 43.

NOTE: To use MIDI note messages for controlling mutes, the MIDI CH should be "on" or any of 1-16. You can set on/off individually with note message, but it has no effects if the MIDI CH is off.

1. Go through the "Changing scenes via external MIDI commands" procedure above for hookup and channel setting.
2. Hold the STORE/COPY key while the MIDI CH indicator is on above the number display.
3. The number display will be flashing "on" or "off". This flashing is to show it's only the individual key muting that will be turned off. Press UP or DOWN to turn the note feature on or off (for this, turn it on).
4. Press SCENE/MIDI CH. The display will return to showing the scene number, and the MIDI CH will go out.
5. On the keyboard, hit the key which has note number 36 harder. The 644 main channel 1 mute should go on.
6. Softly press the same key, and the mute should go off. This procedure should work for each note going up the scale (#37 will turn on/off mute #2, etc.)

In most applications, you will not directly address the 644 this way. Instead a sequencer will issue the note commands of different velocities to change the mute settings. Also, the 644 issues its own note commands, so you can write a sequence by "playing" the mutes of the 644 into the sequencer. The Note On command is followed very quickly by a Note Off command (gate time of each note on is 1); if you hook the MIDI OUT of the 644 to a keyboard, you may be able to hear the short notes that result when you turn a MUTE on/off.

To turn note muting off: Go through steps 2-4 above, leaving the display in the "of" position.

NOTE:

When you set the MIDI channel of the 644 to omni "ON", the 644 transmits MIDI commands on channel 1 and receives external commands on all the 1-16 channels.

Specifications

MECHANICAL CHARACTERISTICS

Tape	Compact cassette (C-30 to 90), Hi-Bias type II (CrO ₂) tape
Track Format	4-track, 4-channel, single directional record/play
Head Configuration	1 4-channel record/play (Permalloy), 1 4-channel erase (ferrite)
Motor	1 DC servo capstan motor, 1 DC reel motor, 1 DC ancillary motor
Tape Speed	9.5 cm/sec., 3-1/2 ips (HIGH) and 4.8 cm/sec., 1-7/8 ips (LOW), ±1.0 %
Pitch Control	±12 % (approx.)
Wow and Flutter	HIGH: 0.04 % WRMS, ±0.06 % W. PEAK LOW: 0.06 % WRMS, ±0.1 % W. PEAK
Fast Winding Time	80 sec. (approx.) with C-60
Power Supply	DC ±10 V, from the PS-M1 Adapter Unit provided; Consumption 18 W
Dimensions (W x H x D)	516 x 120.5 x 400 mm (20-5/16" x 4-3/4" x 15-3/4") AC Adapter: 113 x 61 x 74 mm (4-7/16" x 2-3/8" x 2-15/16"); AC cord 1800 mm (5.9 ft.), DC cord 1500 mm (4.9 ft.)
Weight	7.2 kg (15-14/16 lbs.); AC adapter 1 kg (2-3/16 lbs.)

ELECTRICAL CHARACTERISTICS

Mixer Section

MIC (LINE A) Input (1/4 Phone Jack x 8)

Source Impedance	Less than 10k ohms
Input Impedance	100k ohms
Nominal Input Level	-50 dBV (3 mV) to -10 dBV (0.3 V), ch's 1/9 thru 6/14; -55 dBV (1.5 mV) to -10 dBV (0.3 V), Ch. 7/15 thru 8/16 +10 dBV (3.0 V), trim min., ch's 1/9 thru 6/14; +8 dBV (2.2 V), trim min., ch's 7/15 thru 8/16
Maximum Input Level	

MIC (BAL) Input (XLR Balanced x 2)

Mic Impedance	Less than 600 ohms
Input Impedance	2.8k ohms
Nominal Input Level	-70 dBV (0.3 mV) to -25 dBV (56 mV)
Maximum Input level	-7 dBV (0.4 V), trim min.

LINE B Input (1/4 Phone Jack x 8)

Input Impedance	10k ohms
Nominal Input Level	-10 dBV (0.3 V)
Maximum Input Level	+10 dBV (3.0 V)

INSERT (1/4 Phone Jack x 8)

- Send (Tip) -	
Output Impedance	100 ohms
Nominal Load Impedance	10k ohms
Minimum Load Impedance	2k ohms
Nominal Output Level	-10 dBV (0.3 V)
Maximum Output Level	+10 dBV (3.0 V)
- Receive (Ring) -	
Input Impedance	5k ohms
Nominal Input Level	-10 dBV (0.3 V)
Maximum Input Level	+10 dBV (3.0 V)

EFFECT RETURN (1/4 Phone Jack x 4)

Input Impedance	20k ohms
Nominal Input Level	-10 dBV (0.3 V)
Minimum Input Level	-20 dBV (0.1 V)

GROUP OUT (RCA Jack x 4)

Output Impedance	100 ohms
Nominal Load Impedance	10k ohms
Minimum Load Impedance	2k ohms
Nominal Output Level	-10 dBV (0.3 V)
Maximum Output Level	+10 dBV (3.0 V)

AUX OUT (1/4 Phone Jack x 2)

Output Impedance	100 ohms
Nominal Load Impedance	10k ohms
Minimum Load Impedance	2k ohms
Nominal Output Level	-10 dBV (0.3 V)
Maximum Output Level	+10 dBV (3.0 V)

DUAL OUT (1/4 Phone Jack x 2)

Output Impedance	100 ohms
Nominal Load Impedance	10k ohms
Minimum Load Impedance	2k ohms
Nominal Output Level	-10 dBV (0.3 V)
Maximum Output Level	+10 dBV (3.0 V)

MONITOR OUT (RCA Jack x 2)

Output Impedance	100 ohms
Nominal Load Impedance	10k ohms
Minimum Load Impedance	2k ohms
Nominal Output Level	-10 dBV (0.3 V)
Maximum Output Level	+10 dBV (3.0 V)

PHONES OUT (1/4 Phone Jack x 2)

Nominal Load Impedance	8 ohms
Maximum Output Level	100 mW + 100 mW

EQUALIZER

HIGH (Shelving)	10 kHz, ± 12 dB
MID (Peaking)	250 Hz to 5 kHz, sweepable, ± 15 dB
LOW (Shelving)	100 Hz, ± 12 dB

Recorder Section

Record/Play Channel

4 in number

Noise Reduction

dbx NR (all channels on or off, except: channel 4 disconnected from NR for as long as the SYNC switch is on)

TAPE OUT (1/4 Phone Jack x 4)/**EXT SYNC OUT (RCA Jack x 1)**

Output Impedance	100 ohms
Nominal Load Impedance	10k ohms
Minimum Load Impedance	2k ohms
Nominal Output Level	-10 dBV (0.3 V)

EXT SYNC IN (RCA Jack x 1)

Input Impedance	10k ohms
Nominal Input Level	-10 dBV (0.3 V)
Minimum Input Level	-16 dBV (0.15 V)

TYPICAL PERFORMANCES**Mixer Section**

Frequency Response

20 Hz to 20 kHz, +1/-2 dB

Signal-to-Noise Ratio

(at Nominal Input Level)

(UNWTD (20 Hz to 20 kHz)/IHF A WTD)

8 Mics to 1 Group Out

60 dB/62 dB

1 Mic to 1 Group Out

69 dB/74 dB

8 Line B's to 1 Group Out

71 dB/72 dB

1 Line B to 1 Group Out

71 dB/78 dB

Total Harmonic Distortion (THD)

1 Mic to 1 Group Out

0.06 %, at 1 kHz (20 dB above nominal input level, low-pass filter, 30 kHz, inserted)

1 Line B to 1 Group Out

0.04 %, at 1 kHz (nominal input level)

Crosstalk

60 dB, at 1 kHz

Recorder Section

Frequency Response (Overall)

HIGH

40 Hz to 16 kHz, ± 3 dB (without dbx)

LOW

40 Hz to 12.5 kHz, ± 3 dB (without dbx)

Signal-to-Noise Ratio (Overall)

(Ref. to 3 % THD)

(UNWTD (20 Hz to 20 kHz)/IHF A WTD)

HIGH

55 dB/58 dB (without dbx)

LOW

90 dB/93 dB (with dbx)

54 dB/57 dB (without dbx)

88 dB/91 dB (with dbx)

Total Harmonic Distortion

HIGH

1.0 % (400 Hz, 0 dB, with dbx)

LOW

1.0 % (400 Hz, 0 dB, with dbx)

Crosstalk (adjacent channels)	70 dB (with dbx); 50 dB (without dbx) (1 kHz, 0 dB)
Erasure	65 dB (1 kHz, +10 dB)

In these specifications, 0 dBV is referenced to 1.0 Volt rms. Actual voltage levels are also given in parenthesis. To calculate the 0 dB = 0.775 Volt reference level (i.e., 0 dBu or 0 dBm in a 600 ohm circuit) add 2.2 dB to the listed dBV value, i.e., 0 dBV = +1.0 volt = +2.2 dBm. Changes in specifications and features may be made without notice or obligation.

* dbx is a registered trademark of dbx Incorporated.

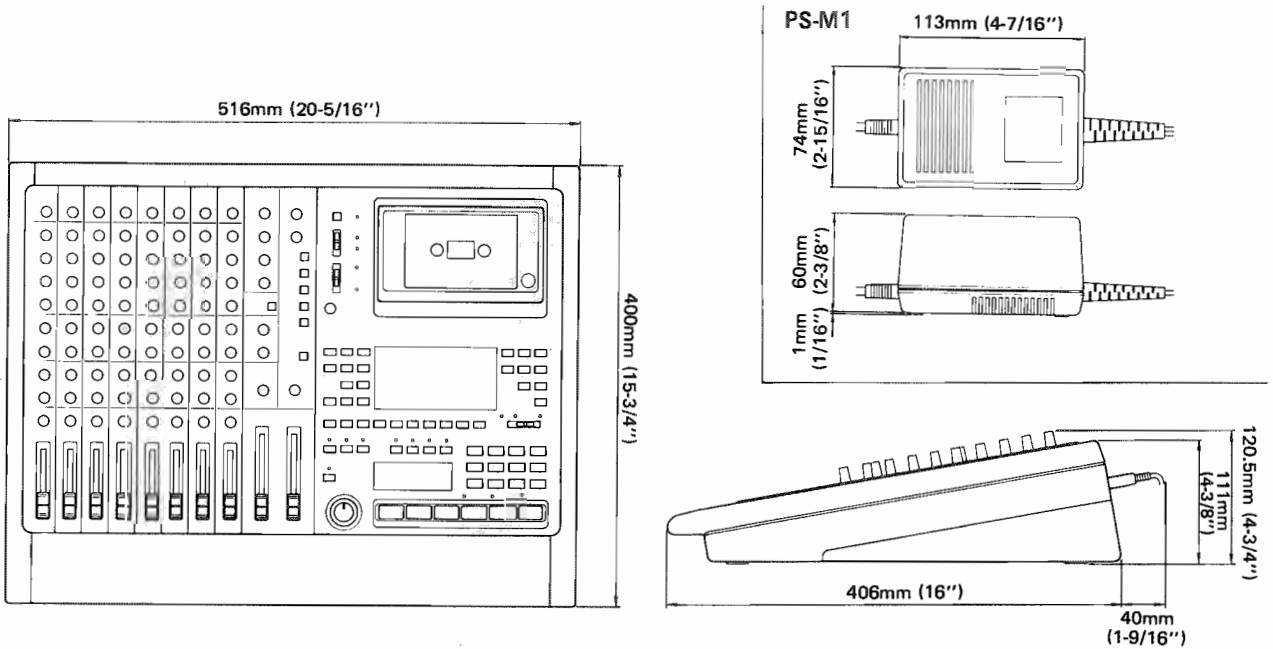

Optional Accessories

RC-88 Remote Control Unit

The RC-88 has duplicates of the rehearsal/auto punch-in and auto-locator controls in addition to the basic transport controls. The cable length is 5 meters (15 ft.).

(The RC-88 includes REC FUNCTIONS 5-8 and INSERT. On the Midistudio 644 they have no effect as the 644 does not have the counterparts.)

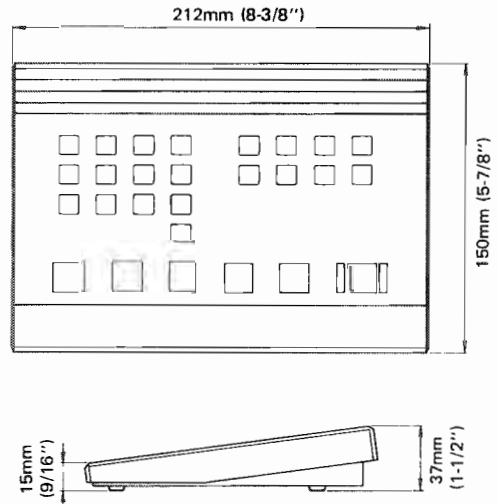

RC-30P Remote Foot Switch



E-3 Head Demagnetizer



RC-60P Remote Foot Switch

The RC-60P has double function and controls both the scene displays and as with the RC-30P, punch-in/out operations.

MTS-1000 MIDiZER

The MTS-1000 is a "Multi-Synchronizer" containing a SMPTE tape transport synchronizer combined with a MIDI-to-SMPTE synchronizer in a single low-cost unit. It is used to make different machines – in this case tape transports and sequencers or rhythm units – play at exactly the same rate of speed, from any desired starting point. This is called "chase-lock" capability. When the MIDiZER is connected to these other units, it becomes the all-in-one master controller for the system.

(Available Summer 1989.)



TZ-261 Cleaning Kit (Except U.S.)



HC Head Cleaner & RC Rubber Cleaner (U.S. only)



PW-2Y/PW-4Y Insertion Cable



Block Diagram

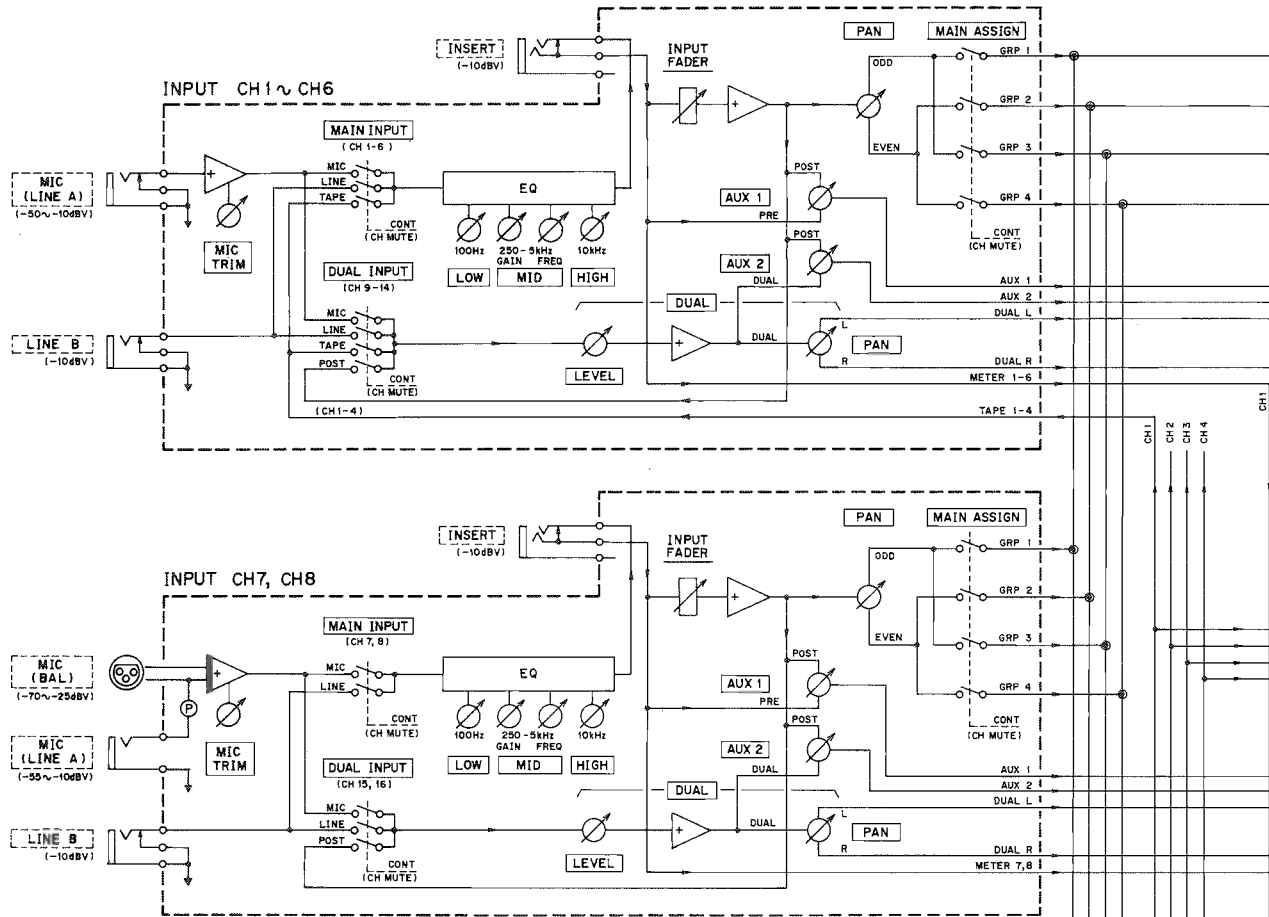

NOTE

- UNIT 0dBV = 1 Vrms
- OPERATIONAL LEVEL -10dBV
- SYMBOLS

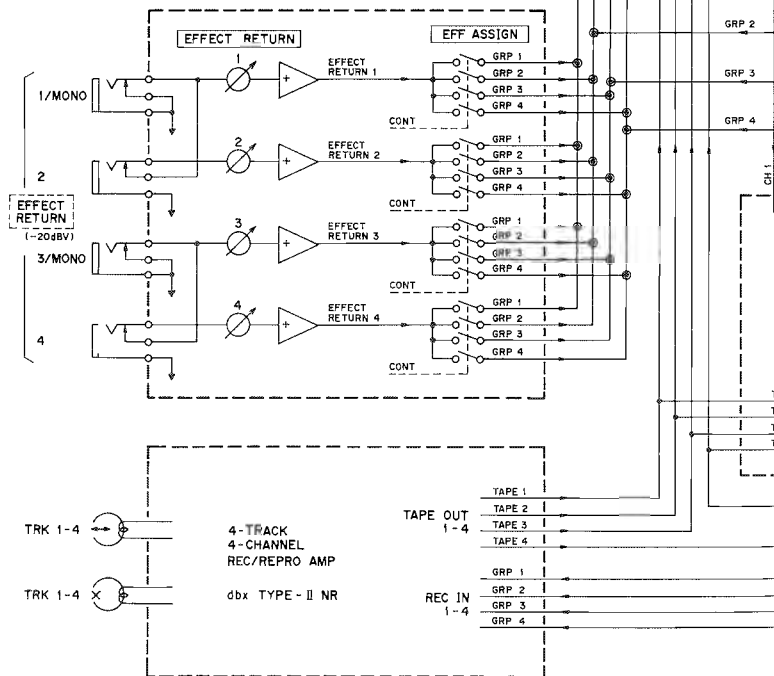

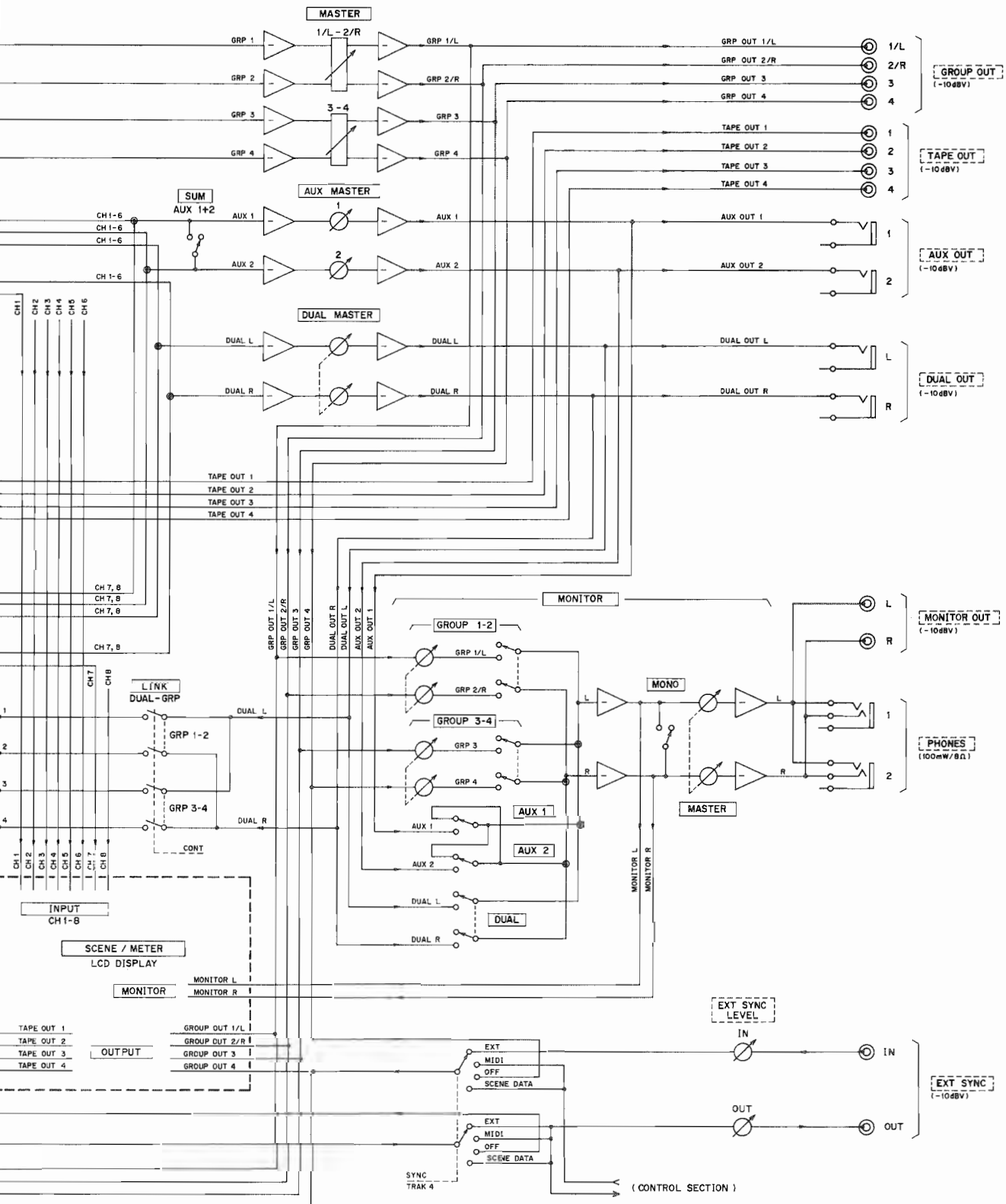

MIXER SECTION

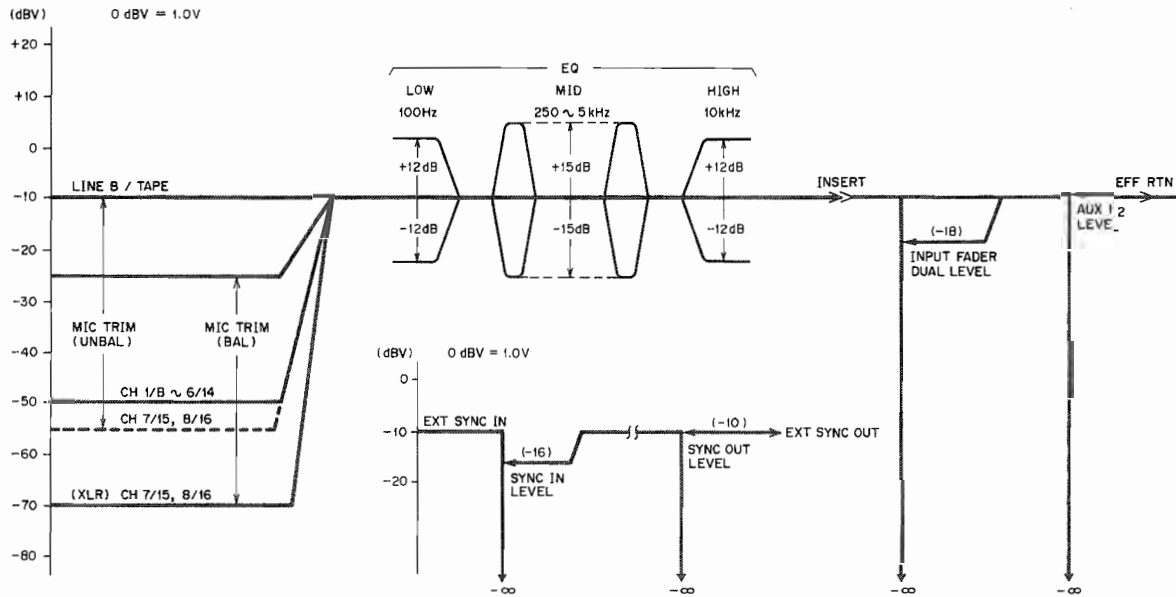

RECORDER SECTION

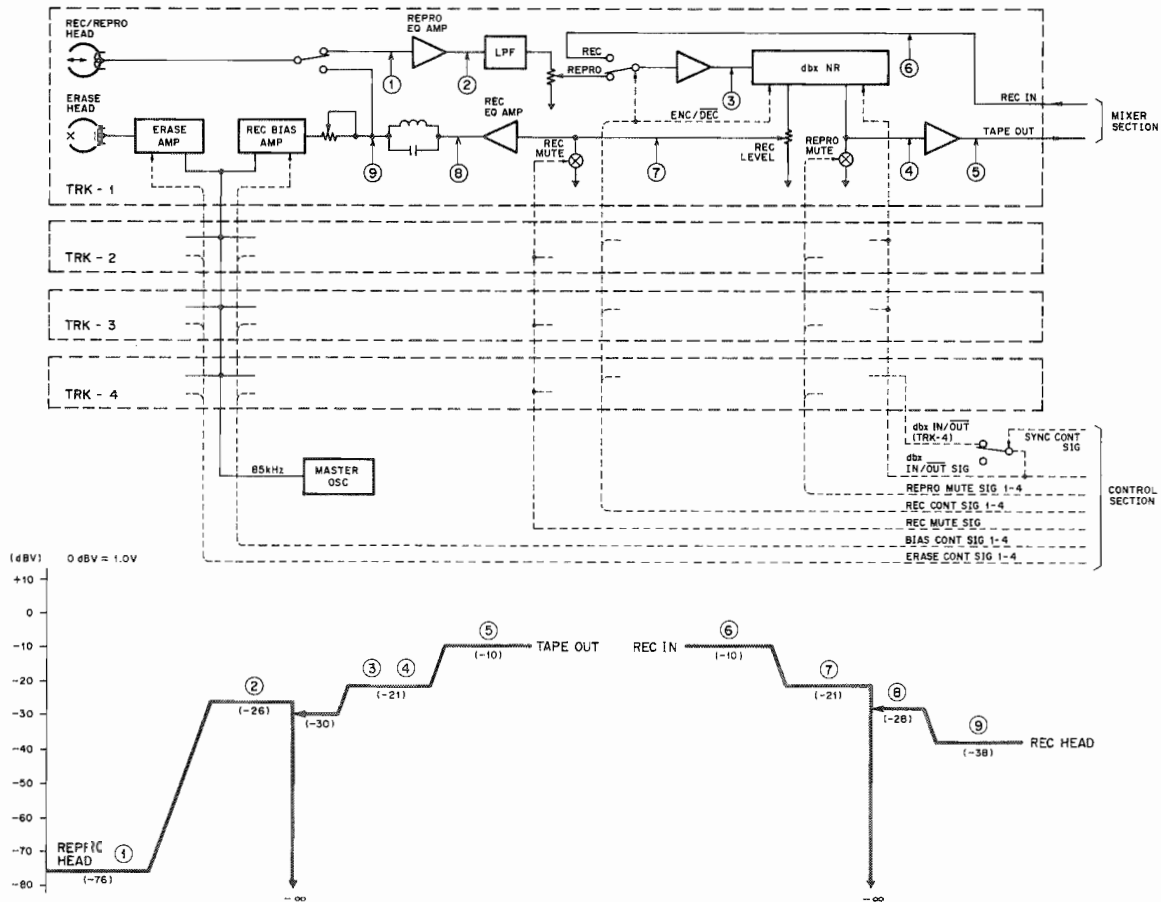

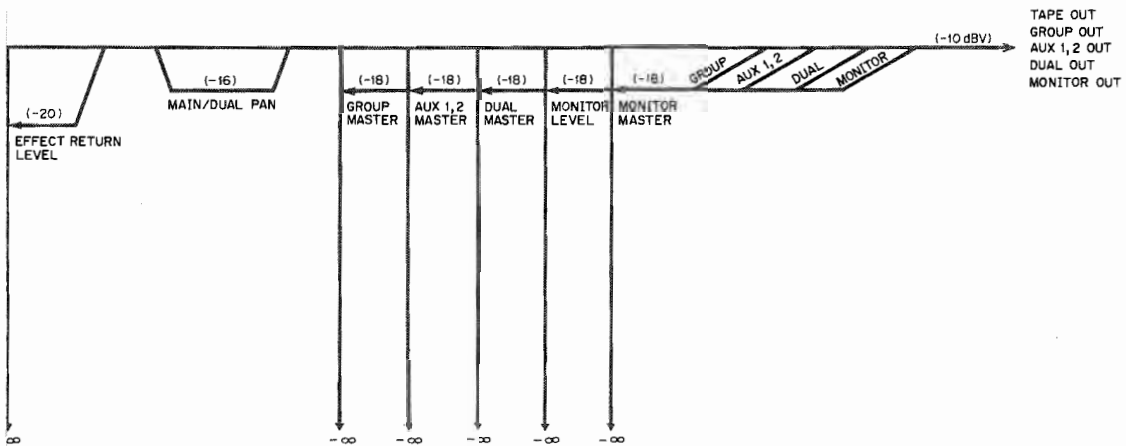

MIDI BLOCK DIAGRAM

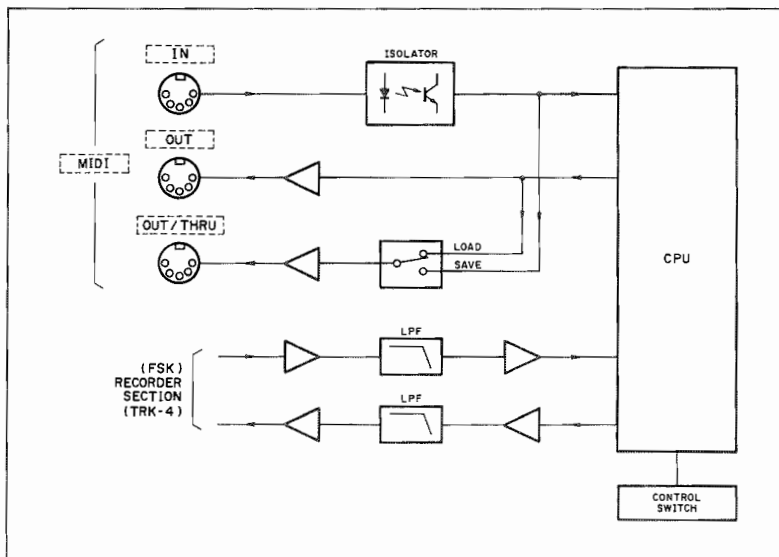

Function		Transmitted	Recognized	Remarks
Basic Channel	Default	1-16	1-16	memorized trans./recog. on common ch
	Changed	1-16	1-16	
Mode	Default	×	×	memorized OMNI On/Off
	Messages	×	×	
	Altered	×	×	
Note Number	: True Voice	36-43	36-43	
		36-43	×	
Velocity	Note ON	○ 9nH, v=32, 96	○ v=1 - 127	enable On/Off memorized
	Note OFF	○ 9nH, v=00	×	
After Touch	Key's	×	×	
	Ch's	×	×	
Pitch Bender		×	×	
Control Change		×	×	
Prog Change	: True #	○	○	Scene No=1-99 (PGM No=0-98)
		○	00-98	
System Exclusive		○	○	SCENE DATA
System Common	: Song Pos	○	×	
	: Song Sel	×	×	
	: Tune	×	×	
System Real Time	: Clock	○	○	*Continue not recognized
	: Commands	○	○*	
Aux Messages	: Local ON/OFF	×	×	
	: All Notes Off	×	×	
	: Active Sense	×	×	
	: Reset	×	×	
Notes				

Mode 1 : OMNI ON, POLY
 Mode 3 : OMNI OFF, POLY

Mode 2 : OMNI ON, MONO
 Mode 4 : OMNI OFF, MONO

○ : Yes
 × : No

Factory Preset Scenes

01-04: Assignments Only to One Group For Tracking and Overdubbing; Main channels 1-8 and Effect Returns 1-4 are all assigned to one group; Dual channels 9-12 are fed with Tape Returns for monitor.

01

CHANNEL/INPUT	1	2	3	4	5	6	7	8	MONITOR
CHANNEL MUTE	<input type="checkbox"/>	<input type="checkbox"/>	<input type="checkbox"/>	<input type="checkbox"/>	<input type="checkbox"/>	<input type="checkbox"/>	<input type="checkbox"/>	<input type="checkbox"/>	L R dB
ASSIGN GRP 1	<input checked="" type="checkbox"/>	<input checked="" type="checkbox"/>	<input checked="" type="checkbox"/>	<input checked="" type="checkbox"/>	<input checked="" type="checkbox"/>	<input checked="" type="checkbox"/>	<input checked="" type="checkbox"/>	<input checked="" type="checkbox"/>	SCENE 01
MAIN GRP 2	<input type="checkbox"/>	<input type="checkbox"/>	<input type="checkbox"/>	<input type="checkbox"/>	<input type="checkbox"/>	<input type="checkbox"/>	<input type="checkbox"/>	<input type="checkbox"/>	+8
GRP 3	<input type="checkbox"/>	<input type="checkbox"/>	<input type="checkbox"/>	<input type="checkbox"/>	<input type="checkbox"/>	<input type="checkbox"/>	<input type="checkbox"/>	<input type="checkbox"/>	6
GRP 4	<input type="checkbox"/>	<input type="checkbox"/>	<input type="checkbox"/>	<input type="checkbox"/>	<input type="checkbox"/>	<input type="checkbox"/>	<input type="checkbox"/>	<input type="checkbox"/>	3
INPUT MIC	<input checked="" type="checkbox"/>	<input checked="" type="checkbox"/>	<input checked="" type="checkbox"/>	<input checked="" type="checkbox"/>	<input checked="" type="checkbox"/>	<input checked="" type="checkbox"/>	<input checked="" type="checkbox"/>	<input checked="" type="checkbox"/>	0
MAIN LINE	<input type="checkbox"/>	<input type="checkbox"/>	<input type="checkbox"/>	<input type="checkbox"/>	<input type="checkbox"/>	<input type="checkbox"/>	<input type="checkbox"/>	<input type="checkbox"/>	3
TAPE	<input type="checkbox"/>	<input type="checkbox"/>	<input type="checkbox"/>	<input type="checkbox"/>	<input type="checkbox"/>	<input type="checkbox"/>	<input type="checkbox"/>	<input type="checkbox"/>	6
	<input type="checkbox"/>	<input type="checkbox"/>	<input type="checkbox"/>	<input type="checkbox"/>	<input type="checkbox"/>	<input type="checkbox"/>	<input type="checkbox"/>	<input type="checkbox"/>	10
	<input type="checkbox"/>	<input type="checkbox"/>	<input type="checkbox"/>	<input type="checkbox"/>	<input type="checkbox"/>	<input type="checkbox"/>	<input type="checkbox"/>	<input type="checkbox"/>	-20
OUTPUT	1	2	3	4	1/L	2/R	3	4	
	TAPE				GROUP				

03

CHANNEL/INPUT	1	2	3	4	5	6	7	8	MONITOR
CHANNEL MUTE	<input type="checkbox"/>	<input type="checkbox"/>	<input type="checkbox"/>	<input type="checkbox"/>	<input type="checkbox"/>	<input type="checkbox"/>	<input type="checkbox"/>	<input type="checkbox"/>	L R dB
ASSIGN GRP 1	<input type="checkbox"/>	<input type="checkbox"/>	<input type="checkbox"/>	<input type="checkbox"/>	<input type="checkbox"/>	<input type="checkbox"/>	<input type="checkbox"/>	<input type="checkbox"/>	SCENE 03
MAIN GRP 2	<input type="checkbox"/>	<input type="checkbox"/>	<input type="checkbox"/>	<input type="checkbox"/>	<input type="checkbox"/>	<input type="checkbox"/>	<input type="checkbox"/>	<input type="checkbox"/>	+8
GRP 3	<input type="checkbox"/>	<input type="checkbox"/>	<input type="checkbox"/>	<input type="checkbox"/>	<input type="checkbox"/>	<input type="checkbox"/>	<input type="checkbox"/>	<input type="checkbox"/>	6
GRP 4	<input checked="" type="checkbox"/>	<input checked="" type="checkbox"/>	<input checked="" type="checkbox"/>	<input checked="" type="checkbox"/>	<input checked="" type="checkbox"/>	<input checked="" type="checkbox"/>	<input checked="" type="checkbox"/>	<input checked="" type="checkbox"/>	3
INPUT MIC	<input checked="" type="checkbox"/>	<input checked="" type="checkbox"/>	<input checked="" type="checkbox"/>	<input checked="" type="checkbox"/>	<input checked="" type="checkbox"/>	<input checked="" type="checkbox"/>	<input checked="" type="checkbox"/>	<input checked="" type="checkbox"/>	0
MAIN LINE	<input type="checkbox"/>	<input type="checkbox"/>	<input type="checkbox"/>	<input type="checkbox"/>	<input type="checkbox"/>	<input type="checkbox"/>	<input type="checkbox"/>	<input type="checkbox"/>	3
TAPE	<input type="checkbox"/>	<input type="checkbox"/>	<input type="checkbox"/>	<input type="checkbox"/>	<input type="checkbox"/>	<input type="checkbox"/>	<input type="checkbox"/>	<input type="checkbox"/>	6
	<input type="checkbox"/>	<input type="checkbox"/>	<input type="checkbox"/>	<input type="checkbox"/>	<input type="checkbox"/>	<input type="checkbox"/>	<input type="checkbox"/>	<input type="checkbox"/>	10
	<input type="checkbox"/>	<input type="checkbox"/>	<input type="checkbox"/>	<input type="checkbox"/>	<input type="checkbox"/>	<input type="checkbox"/>	<input type="checkbox"/>	<input type="checkbox"/>	-20
OUTPUT	1	2	3	4	1/L	2/R	3	4	
	TAPE				GROUP				

CHANNEL/INPUT	1	2	3	4	5	6	7	8	MONITOR
CHANNEL MUTE	<input type="checkbox"/>	<input type="checkbox"/>	<input type="checkbox"/>	<input type="checkbox"/>	<input type="checkbox"/>	<input type="checkbox"/>	<input type="checkbox"/>	<input type="checkbox"/>	L R dB
ASSIGN GRP 1	<input checked="" type="checkbox"/>	<input checked="" type="checkbox"/>	<input checked="" type="checkbox"/>	<input checked="" type="checkbox"/>	<input checked="" type="checkbox"/>	<input checked="" type="checkbox"/>	<input checked="" type="checkbox"/>	<input checked="" type="checkbox"/>	SCENE 01
EFF GRP 2	<input type="checkbox"/>	<input type="checkbox"/>	<input type="checkbox"/>	<input type="checkbox"/>	<input type="checkbox"/>	<input type="checkbox"/>	<input type="checkbox"/>	<input type="checkbox"/>	+8
GRP 3	<input type="checkbox"/>	<input type="checkbox"/>	<input type="checkbox"/>	<input type="checkbox"/>	<input type="checkbox"/>	<input type="checkbox"/>	<input type="checkbox"/>	<input type="checkbox"/>	6
GRP 4	<input type="checkbox"/>	<input type="checkbox"/>	<input type="checkbox"/>	<input type="checkbox"/>	<input type="checkbox"/>	<input type="checkbox"/>	<input type="checkbox"/>	<input type="checkbox"/>	3
INPUT MIC	<input checked="" type="checkbox"/>	<input checked="" type="checkbox"/>	<input checked="" type="checkbox"/>	<input checked="" type="checkbox"/>	<input checked="" type="checkbox"/>	<input checked="" type="checkbox"/>	<input checked="" type="checkbox"/>	<input checked="" type="checkbox"/>	0
DUAL LINE	<input type="checkbox"/>	<input type="checkbox"/>	<input type="checkbox"/>	<input type="checkbox"/>	<input type="checkbox"/>	<input type="checkbox"/>	<input type="checkbox"/>	<input type="checkbox"/>	3
TAPE	<input type="checkbox"/>	<input type="checkbox"/>	<input type="checkbox"/>	<input type="checkbox"/>	<input type="checkbox"/>	<input type="checkbox"/>	<input type="checkbox"/>	<input type="checkbox"/>	6
POST	<input type="checkbox"/>	<input type="checkbox"/>	<input type="checkbox"/>	<input type="checkbox"/>	<input type="checkbox"/>	<input type="checkbox"/>	<input type="checkbox"/>	<input type="checkbox"/>	10
	<input type="checkbox"/>	<input type="checkbox"/>	<input type="checkbox"/>	<input type="checkbox"/>	<input type="checkbox"/>	<input type="checkbox"/>	<input type="checkbox"/>	<input type="checkbox"/>	-20
OUTPUT	1	2	3	4	1/L	2/R	3	4	
	TAPE				GROUP				

CHANNEL/INPUT	1	2	3	4	5	6	7	8	MONITOR
CHANNEL MUTE	<input type="checkbox"/>	<input type="checkbox"/>	<input type="checkbox"/>	<input type="checkbox"/>	<input type="checkbox"/>	<input type="checkbox"/>	<input type="checkbox"/>	<input type="checkbox"/>	L R dB
ASSIGN GRP 1	<input type="checkbox"/>	<input type="checkbox"/>	<input type="checkbox"/>	<input type="checkbox"/>	<input type="checkbox"/>	<input type="checkbox"/>	<input type="checkbox"/>	<input type="checkbox"/>	SCENE 03
EFF GRP 2	<input checked="" type="checkbox"/>	<input checked="" type="checkbox"/>	<input checked="" type="checkbox"/>	<input checked="" type="checkbox"/>	<input checked="" type="checkbox"/>	<input checked="" type="checkbox"/>	<input checked="" type="checkbox"/>	<input checked="" type="checkbox"/>	+8
GRP 3	<input type="checkbox"/>	<input type="checkbox"/>	<input type="checkbox"/>	<input type="checkbox"/>	<input type="checkbox"/>	<input type="checkbox"/>	<input type="checkbox"/>	<input type="checkbox"/>	6
GRP 4	<input type="checkbox"/>	<input type="checkbox"/>	<input type="checkbox"/>	<input type="checkbox"/>	<input type="checkbox"/>	<input type="checkbox"/>	<input type="checkbox"/>	<input type="checkbox"/>	3
INPUT MIC	<input checked="" type="checkbox"/>	<input checked="" type="checkbox"/>	<input checked="" type="checkbox"/>	<input checked="" type="checkbox"/>	<input checked="" type="checkbox"/>	<input checked="" type="checkbox"/>	<input checked="" type="checkbox"/>	<input checked="" type="checkbox"/>	0
DUAL LINE	<input type="checkbox"/>	<input type="checkbox"/>	<input type="checkbox"/>	<input type="checkbox"/>	<input type="checkbox"/>	<input type="checkbox"/>	<input type="checkbox"/>	<input type="checkbox"/>	3
TAPE	<input type="checkbox"/>	<input type="checkbox"/>	<input type="checkbox"/>	<input type="checkbox"/>	<input type="checkbox"/>	<input type="checkbox"/>	<input type="checkbox"/>	<input type="checkbox"/>	6
POST	<input type="checkbox"/>	<input type="checkbox"/>	<input type="checkbox"/>	<input type="checkbox"/>	<input type="checkbox"/>	<input type="checkbox"/>	<input type="checkbox"/>	<input type="checkbox"/>	10
	<input type="checkbox"/>	<input type="checkbox"/>	<input type="checkbox"/>	<input type="checkbox"/>	<input type="checkbox"/>	<input type="checkbox"/>	<input type="checkbox"/>	<input type="checkbox"/>	-20
OUTPUT	1	2	3	4	1/L	2/R	3	4	
	TAPE				GROUP				

02

CHANNEL/INPUT	1	2	3	4	5	6	7	8	MONITOR
CHANNEL MUTE	<input type="checkbox"/>	<input type="checkbox"/>	<input type="checkbox"/>	<input type="checkbox"/>	<input type="checkbox"/>	<input type="checkbox"/>	<input type="checkbox"/>	<input type="checkbox"/>	L R dB
ASSIGN GRP 1	<input type="checkbox"/>	<input type="checkbox"/>	<input type="checkbox"/>	<input type="checkbox"/>	<input type="checkbox"/>	<input type="checkbox"/>	<input type="checkbox"/>	<input type="checkbox"/>	SCENE 02
MAIN GRP 2	<input checked="" type="checkbox"/>	<input checked="" type="checkbox"/>	<input checked="" type="checkbox"/>	<input checked="" type="checkbox"/>	<input checked="" type="checkbox"/>	<input checked="" type="checkbox"/>	<input checked="" type="checkbox"/>	<input checked="" type="checkbox"/>	+8
GRP 3	<input type="checkbox"/>	<input type="checkbox"/>	<input type="checkbox"/>	<input type="checkbox"/>	<input type="checkbox"/>	<input type="checkbox"/>	<input type="checkbox"/>	<input type="checkbox"/>	6
GRP 4	<input type="checkbox"/>	<input type="checkbox"/>	<input type="checkbox"/>	<input type="checkbox"/>	<input type="checkbox"/>	<input type="checkbox"/>	<input type="checkbox"/>	<input type="checkbox"/>	3
INPUT MIC	<input checked="" type="checkbox"/>	<input checked="" type="checkbox"/>	<input checked="" type="checkbox"/>	<input checked="" type="checkbox"/>	<input checked="" type="checkbox"/>	<input checked="" type="checkbox"/>	<input checked="" type="checkbox"/>	<input checked="" type="checkbox"/>	0
MAIN LINE	<input type="checkbox"/>	<input type="checkbox"/>	<input type="checkbox"/>	<input type="checkbox"/>	<input type="checkbox"/>	<input type="checkbox"/>	<input type="checkbox"/>	<input type="checkbox"/>	3
TAPE	<input type="checkbox"/>	<input type="checkbox"/>	<input type="checkbox"/>	<input type="checkbox"/>	<input type="checkbox"/>	<input type="checkbox"/>	<input type="checkbox"/>	<input type="checkbox"/>	6
	<input type="checkbox"/>	<input type="checkbox"/>	<input type="checkbox"/>	<input type="checkbox"/>	<input type="checkbox"/>	<input type="checkbox"/>	<input type="checkbox"/>	<input type="checkbox"/>	10
	<input type="checkbox"/>	<input type="checkbox"/>	<input type="checkbox"/>	<input type="checkbox"/>	<input type="checkbox"/>	<input type="checkbox"/>	<input type="checkbox"/>	<input type="checkbox"/>	-20
OUTPUT	1	2	3	4	1/L	2/R	3	4	
	TAPE				GROUP				

04

CHANNEL/INPUT	1	2	3	4	5	6	7	8	MONITOR
CHANNEL MUTE	<input type="checkbox"/>	<input type="checkbox"/>	<input type="checkbox"/>	<input type="checkbox"/>	<input type="checkbox"/>	<input type="checkbox"/>	<input type="checkbox"/>	<input type="checkbox"/>	L R dB
ASSIGN GRP 1	<input type="checkbox"/>	<input type="checkbox"/>	<input type="checkbox"/>	<input type="checkbox"/>	<input type="checkbox"/>	<input type="checkbox"/>	<input type="checkbox"/>	<input type="checkbox"/>	SCENE 04
MAIN GRP 2	<input type="checkbox"/>	<input type="checkbox"/>	<input type="checkbox"/>	<input type="checkbox"/>	<input type="checkbox"/>	<input type="checkbox"/>	<input type="checkbox"/>	<input type="checkbox"/>	+8
GRP 3	<input type="checkbox"/>	<input type="checkbox"/>	<input type="checkbox"/>	<input type="checkbox"/>	<input type="checkbox"/>	<input type="checkbox"/>	<input type="checkbox"/>	<input type="checkbox"/>	6
GRP 4	<input checked="" type="checkbox"/>	<input checked="" type="checkbox"/>	<input checked="" type="checkbox"/>	<input checked="" type="checkbox"/>	<input checked="" type="checkbox"/>	<input checked="" type="checkbox"/>	<input checked="" type="checkbox"/>	<input checked="" type="checkbox"/>	3
INPUT MIC	<input checked="" type="checkbox"/>	<input checked="" type="checkbox"/>	<input checked="" type="checkbox"/>	<input checked="" type="checkbox"/>	<input checked="" type="checkbox"/>	<input checked="" type="checkbox"/>	<input checked="" type="checkbox"/>	<input checked="" type="checkbox"/>	0
MAIN LINE	<input type="checkbox"/>	<input type="checkbox"/>	<input type="checkbox"/>	<input type="checkbox"/>	<input type="checkbox"/>	<input type="checkbox"/>	<input type="checkbox"/>	<input type="checkbox"/>	3
TAPE	<input type="checkbox"/>	<input type="checkbox"/>	<input type="checkbox"/>	<input type="checkbox"/>	<input type="checkbox"/>	<input type="checkbox"/>	<input type="checkbox"/>	<input type="checkbox"/>	6
	<input type="checkbox"/>	<input type="checkbox"/>	<input type="checkbox"/>	<input type="checkbox"/>	<input type="checkbox"/>	<input type="checkbox"/>	<input type="checkbox"/>	<input type="checkbox"/>	10
	<input type="checkbox"/>	<input type="checkbox"/>	<input type="checkbox"/>	<input type="checkbox"/>	<input type="checkbox"/>	<input type="checkbox"/>	<input type="checkbox"/>	<input type="checkbox"/>	-20
OUTPUT	1	2	3	4	1/L	2/R	3	4	
	TAPE				GROUP				

CHANNEL/INPUT	1	2	3	4	5	6	7	8	MONITOR
CHANNEL MUTE	<input type="checkbox"/>	<input type="checkbox"/>	<input type="checkbox"/>	<input type="checkbox"/>	<input type="checkbox"/>	<input type="checkbox"/>	<input type="checkbox"/>	<input type="checkbox"/>	L R dB
ASSIGN GRP 1	<input checked="" type="checkbox"/>	<input checked="" type="checkbox"/>	<input checked="" type="checkbox"/>	<input checked="" type="checkbox"/>	<input checked="" type="checkbox"/>	<input checked="" type="checkbox"/>	<input checked="" type="checkbox"/>	<input checked="" type="checkbox"/>	SCENE 02
EFF GRP 2	<input type="checkbox"/>	<input type="checkbox"/>	<input type="checkbox"/>	<input type="checkbox"/>	<input type="checkbox"/>	<input type="checkbox"/>	<input type="checkbox"/>	<input type="checkbox"/>	+8
GRP 3	<input type="checkbox"/>	<input type="checkbox"/>	<input type="checkbox"/>	<input type="checkbox"/>	<input type="checkbox"/>	<input type="checkbox"/>	<input type="checkbox"/>	<input type="checkbox"/>	6
GRP 4	<input type="checkbox"/>	<input type="checkbox"/>	<input type="checkbox"/>	<input type="checkbox"/>	<input type="checkbox"/>	<input type="checkbox"/>	<input type="checkbox"/>	<input type="checkbox"/>	3
INPUT MIC	<input checked="" type="checkbox"/>	<input checked="" type="checkbox"/>	<input checked="" type="checkbox"/>	<input checked="" type="checkbox"/>	<input checked="" type="checkbox"/>	<input checked="" type="checkbox"/>	<input checked="" type="checkbox"/>	<input checked="" type="checkbox"/>	0
DUAL LINE	<input type="checkbox"/>	<input type="checkbox"/>	<input type="checkbox"/>	<input type="checkbox"/>	<input type="checkbox"/>	<input type="checkbox"/>	<input type="checkbox"/>	<input type="checkbox"/>	3
TAPE	<input type="checkbox"/>	<input type="checkbox"/>	<input type="checkbox"/>	<input type="checkbox"/>	<input type="checkbox"/>	<input type="checkbox"/>	<input type="checkbox"/>	<input type="checkbox"/>	6
POST	<input type="checkbox"/>	<input type="checkbox"/>	<input type="checkbox"/>	<input type="checkbox"/>	<input type="checkbox"/>	<input type="checkbox"/>	<input type="checkbox"/>	<input type="checkbox"/>	10
	<input type="checkbox"/>	<input type="checkbox"/>	<input type="checkbox"/>	<input type="checkbox"/>	<input type="checkbox"/>	<input type="checkbox"/>	<input type="checkbox"/>	<input type="checkbox"/>	-20
OUTPUT	1	2	3	4	1/L	2/R	3	4	
	TAPE				GROUP				

CHANNEL/INPUT	1	2	3	4	5	6	7	8	MONITOR
CHANNEL MUTE	<input type="checkbox"/>	<input type="checkbox"/>	<input type="checkbox"/>	<input type="checkbox"/>	<input type="checkbox"/>	<input type="checkbox"/>	<input type="checkbox"/>	<input type="checkbox"/>	L R dB
ASSIGN GRP 1	<input type="checkbox"/>	<input type="checkbox"/>	<input type="checkbox"/>	<input type="checkbox"/>	<input type="checkbox"/>	<input type="checkbox"/>	<input type="checkbox"/>	<input type="checkbox"/>	SCENE 04
EFF GRP 2	<input checked="" type="checkbox"/>	<input checked="" type="checkbox"/>	<input checked="" type="checkbox"/>	<input checked="" type="checkbox"/>	<input checked="" type="checkbox"/>	<input checked="" type="checkbox"/>	<input checked="" type="checkbox"/>	<input checked="" type="checkbox"/>	+8
GRP 3	<input type="checkbox"/>	<input type="checkbox"/>	<input type="checkbox"/>	<input type="checkbox"/>	<input type="checkbox"/>	<input type="checkbox"/>	<input type="checkbox"/>	<input type="checkbox"/>	6
GRP 4	<input type="checkbox"/>	<input type="checkbox"/>	<input type="checkbox"/>	<input type="checkbox"/>	<input type="checkbox"/>	<input type="checkbox"/>	<input type="checkbox"/>	<input type="checkbox"/>	3
INPUT MIC	<input checked="" type="checkbox"/>	<input checked="" type="checkbox"/>	<input checked="" type="checkbox"/>	<input checked="" type="checkbox"/>	<input checked="" type="checkbox"/>	<input checked="" type="checkbox"/>	<input checked="" type="checkbox"/>	<input checked="" type="checkbox"/>	0
DUAL LINE	<input type="checkbox"/>	<input type="checkbox"/>	<input type="checkbox"/>	<input type="checkbox"/>	<input type="checkbox"/>	<input type="checkbox"/>	<input type="checkbox"/>	<input type="checkbox"/>	3
TAPE	<input type="checkbox"/>	<input type="checkbox"/>	<input type="checkbox"/>	<input type="checkbox"/>	<input type="checkbox"/>	<input type="checkbox"/>	<input type="checkbox"/>	<input type="checkbox"/>	6
POST	<input type="checkbox"/>	<input type="checkbox"/>	<input type="checkbox"/>	<input type="checkbox"/>	<input type="checkbox"/>	<input type="checkbox"/>	<input type="checkbox"/>	<input type="checkbox"/>	10
	<input type="checkbox"/>	<input type="checkbox"/>	<input type="checkbox"/>	<input type="checkbox"/>	<input type="checkbox"/>	<input type="checkbox"/>	<input type="checkbox"/>	<input type="checkbox"/>	-20
OUTPUT	1	2	3	4	1/L	2/R	3	4	
	TAPE				GROUP				

05-06: Assignments to Two Groups For Stereo Recording: Dual channels 9-12 used for tape monitor; Dual channels 13-16 receive (left) signal from LINE B (for monitoring virtual (MIDI) instruments or additional effect returns without recording them).

05

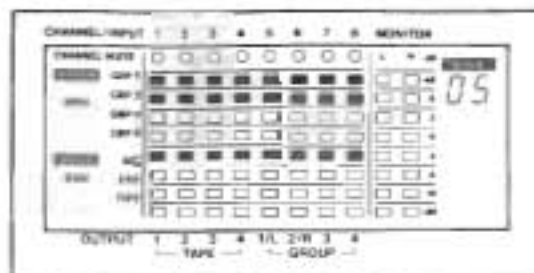

07-08: Assignments to Two Groups, with Dual LINKed
These scenes allow you to record 14 instruments at once onto 2 tracks. The DUAL mixes 8 lines and the MAIN mixes 6 mics to a pair of groups. The opposite pair of groups are used for tape monitoring.

07

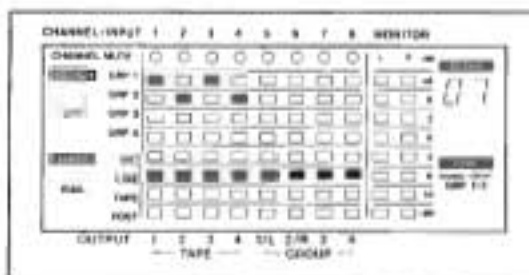
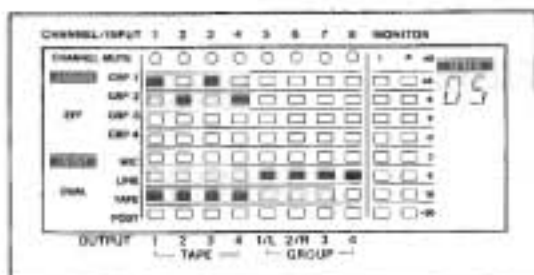
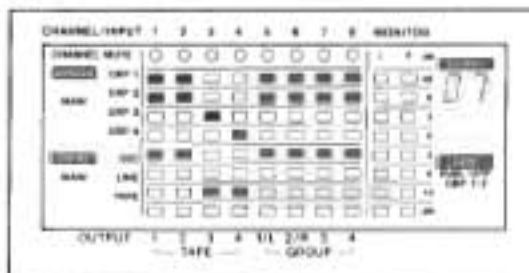

06

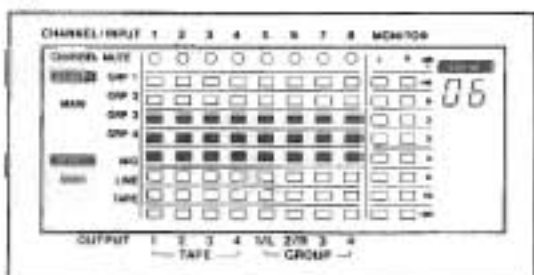

08

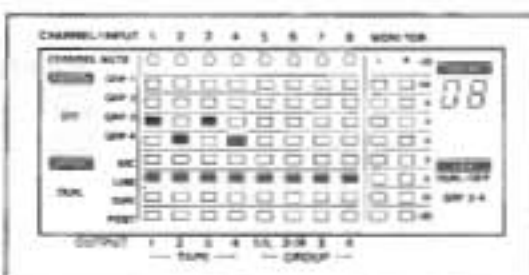
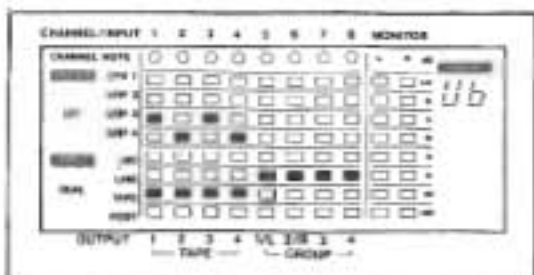
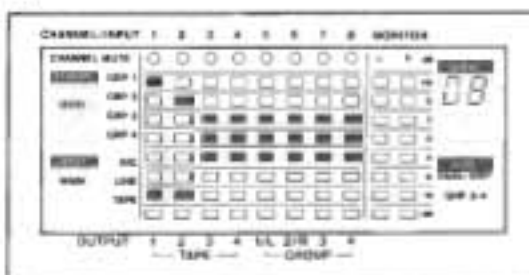

09: Bouncing onto Track 4 Main channels 1-3 are fed with Tracks 1-3, and the remaining Main channels with "live source" plugged into MIC (LINE A) jacks; Dual channel 12 is used for monitoring Track 4.

11: Assignments to All Groups Each MIC (LINE A) input goes to all four groups at once. Leave the pan pots at center, use the RECORD FUNCTION switches to select the track to record on without having to change scenes.

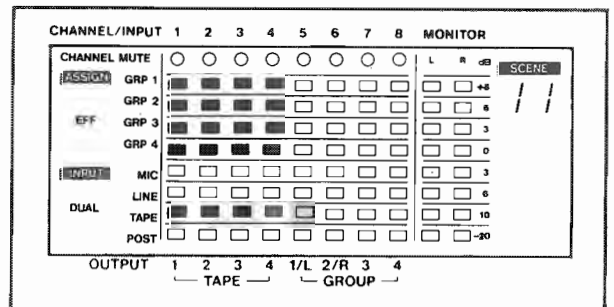
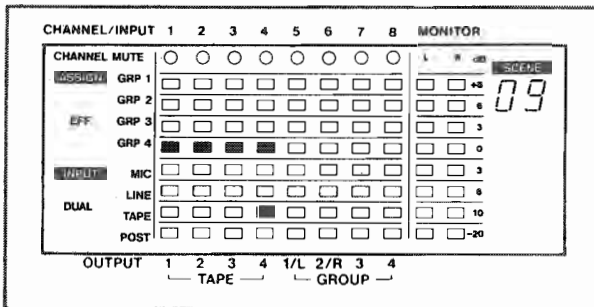
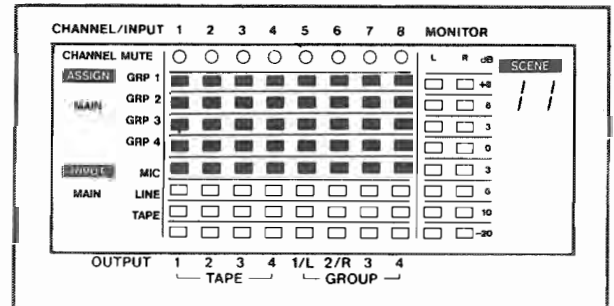
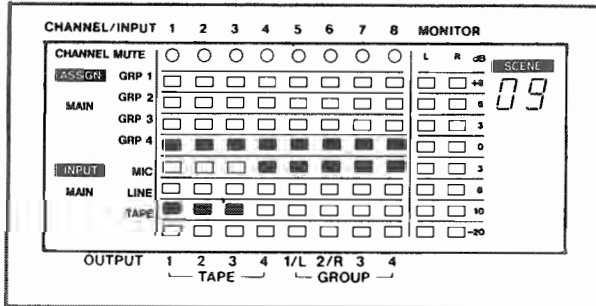

10: Feeding 4 Tracks with Separate Inputs at a Time Dual channels 9-12 allow tape monitor.

12: Mixdown Assignments Four tracks are sent via Main channels 1-4 to Groups 1 and 2; MIC signals plugged into Main channels 5-8 and LINE signals from Dual channels 9-16 can be added to the tape mix; Effect Returns 1 and 3 are assigned to Group 1, and Effect Returns 2 and 4 to Group 2.

